

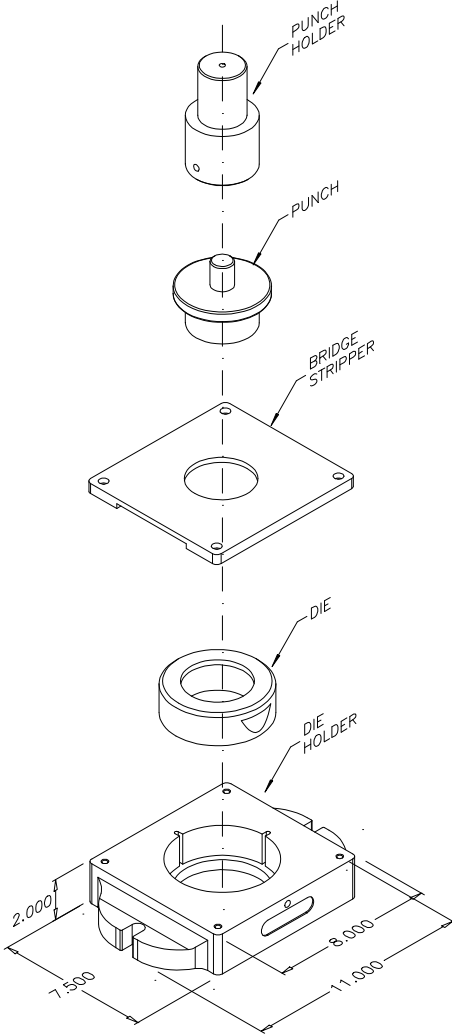

28XX MEDIUM DUTY - Tooling Accessories

This series of holders are designed specifically to support 28XX standard punches and dies, round or shaped. Fits any press for material ranging from .040" to .125" thick.

Ø1.001 to Ø5.000



Hole size Range	Punch Holder Part number	Price ea. (\$CA)
.093 – 2.000	28XXPH1	150.00
2.001 – 3.000	28XXPR2	175.00
3.001 – 4.000	28XXPR3	225.00
4.001 – 5.000	28XXPR4	285.00

Hole size Range	Die Retainer Part number	DIE O/D	Price ea. (\$CA)
1.438 – 2.000	28XXDR1	2 ¾	385.00
2.001 – 2.750	28XXDR2	3 ¾	440.00
2.751 – 4.000	28XXDR3	4 ¾	485.00
4.001 – 5.000	28XXDR4	5 ¾	520.00

Hole size Range	Die Adapter Part number	I/D	O/D	Price (\$CA)
.093 - .812	28XXDA2 **	1 ¼	2 ¾	110.0
.813 – 1.437	28XXDA3**	2 1/8	2 ¾	165.0
1.438 – 2.00	28XXDA4**	2 ¾"	3 3/4	190.0
2.001-2.750	28XXDA5	3 ¾	4 3/4	210.0

Hole size Range	Urethane Stripper	Price ea. (\$CA)
.093 – 1.000	28XXUS1	55.00

Hole size Range	Bridge Stripper	Price ea. (\$CA)
1.001-5.000	BR1 ***	275.00

Ø.093 to Ø1.000

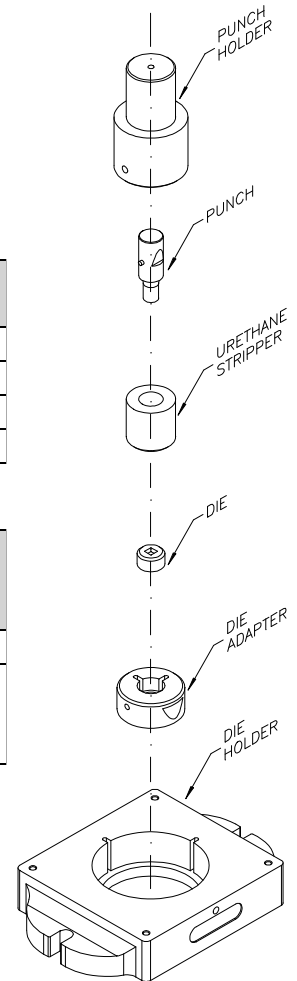

- Notes:** - Maximum Tonnage capacity of this unit is **20 ton's**.
 - See HEAVY-DUTY duty series for applications with greater tonnage.

- * Specify shank diameter when ordering.
- ** For holes ranging from .093" – 1.437" a Die Adapter is required.
- ** Use on 28XXDR1 die retainer only.
- *** Specify: - punch diameter, material thickness & strip width.

Maximum Punch Diameter
 Up to .040" thick = Ø5.000
 Up to .063" thick = Ø4.000
 Up to .125" thick = Ø2.000

Tonnage required for punching = circumference x material thickness x 25 (Answer in Tons)

