



Anchor Lamina Inc.



Lamina Components - Round Mold Products



TABLE OF CONTENTS

Shoulder Bushings

Bronze-Plated – Inch	3
Bronze-Plated – Metric	3
Hardened Steel	4
Self-Lubricating	4
Solid Bronze	5

Straight Bushings

Bronze-Plated -Inch	6
Hardened Steel	6
Self-Lubricating	7
Solid Bronze	8

Ejector Bushings

Bronze-Plated - Inch	9
Bronze-Plated - Metric	9
Self-Lubricating - Inch	10
Self-Lubricating - Metric	10
Solid Bronze	11

Leader Pins

Inch	12
Metric.....	13

Lamina began as a lamination die manufacturer in 1938. During the years from 1938 to the present Lamina has evolved into a manufacturer and distributor of die and mold components. Even though we no longer make dies, we do understand the die and mold maker’s needs and objectives.

We have made it our business to supply quality products in a timely manner at reasonable prices. We know how to compete in the marketplace and supply you with the products you need when you need them.

We introduce this catalog featuring bronze plated, hardened steel and self-lubricating bronze mold bushings and steel pins. It is our purpose to help you become more productive by helping to eliminate your downtime. With the products in stock, we will become your one-stop supplier and deliver the products you require each and every day.

Our catalog is presented in an easy-to-read format that displays the selection of products you need without a lot of extra data.

Anchor Lamina Mission

To be the ‘customer focused’ world class supplier of choice to the metal working and plastics industry.

We will help our customers to compete globally by providing innovative and value added products and services.





Lamina Components

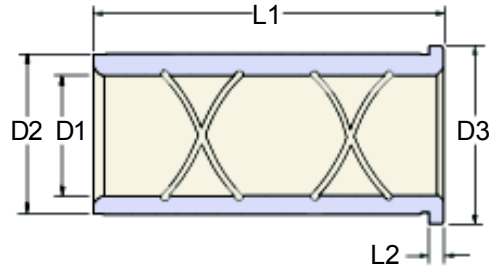
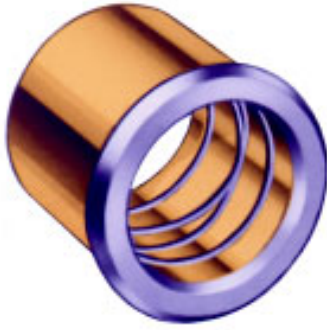

GENERAL DIMENSIONS				
Nom. I.D.	D1 +0.005 -0.000	D2 +0.005 -0.000	D3 +0.00 -0.015	L2 +0.00 -0.005
3/4	.7505	1.1255	1.302	.187
7/8	.8755	1.2505	1.427	.187
1	1.0005	1.3755	1.552	.187
1-1/4	1.2505	1.6255	1.802	.187
1-1/2	1.5005	2.0005	2.177	.187
2	2.0005	2.5005	2.677	.187
2-1/2	2.5005	3.2505	3.427	.187
3	3.0005	3.7505	3.990	.500

SHOULDER BUSHINGS – BRONZE PLATED – INCH								
L1 LENGTH +.031/-0.062	INSIDE DIAMETER							
	3/4	7/8	1	1-1/4	1-1/2	2	2-1/2	3
7/8	LBB-06-07	LBB-07-07	LBB-08-07	LBB-10-07	LBB-12-07			
1-3/8	LBB-06-13	LBB-07-13	LBB-08-13	LBB-10-13	LBB-12-13	LBB-16-13	LBB-20-13	
1-7/8	LBB-06-17	LBB-07-17	LBB-08-17	LBB-10-17	LBB-12-17	LBB-16-17	LBB-20-17	
2-3/8	LBB-06-23	LBB-07-23	LBB-08-23	LBB-10-23	LBB-12-23	LBB-16-23	LBB-20-23	
2-7/8	LBB-06-27	LBB-07-27	LBB-08-27	LBB-10-27	LBB-12-27	LBB-16-27	LBB-20-27	
3-3/8	LBB-06-33	LBB-07-33	LBB-08-33	LBB-10-33	LBB-12-33	LBB-16-33	LBB-20-33	
3-7/8	LBB-06-37	LBB-07-37	LBB-08-37	LBB-10-37	LBB-12-37	LBB-16-37	LBB-20-37	LBB-24-37
4-3/8	LBB-06-43	LBB-07-43	LBB-08-43	LBB-10-43	LBB-12-43	LBB-16-43	LBB-20-43	
4-7/8	LBB-06-47	LBB-07-47	LBB-08-47	LBB-10-47	LBB-12-47	LBB-16-47	LBB-20-47	LBB-24-47
5-7/8	LBB-06-57	LBB-07-57	LBB-08-57	LBB-10-57	LBB-12-57	LBB-16-57	LBB-20-57	LBB-24-57
7-7/8								LBB-24-77

Precision-ground steel with exclusive Lamina Bronze plating. These are the only bushings that give you oil grooves and a true bushing surface that extends the full length of the bushing

Lamina-Bronze bushings will operate smoother and longer than plain steel bushings ever could. Whatever lubricant is used, it is distributed throughout the bearing surface by the figure-8 oil groove system. The bronze surface will not gall.

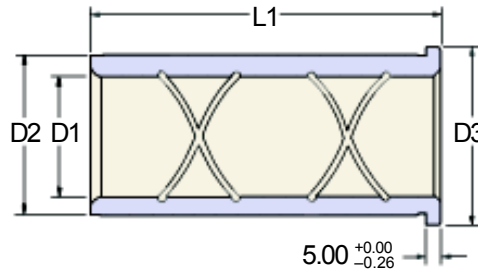

GENERAL DIMENSIONS			
Nom I.D.	D1 +0.013 -0.000	D2 +0.013 -0.000	D3 +0.00 -0.13
20	20.013	26.013	28.00
25	25.013	32.013	35.00
30	30.013	38.013	41.00
40	40.013	50.013	53.00
50	50.013	60.013	63.00
60	60.013	70.013	73.00

SHOULDER BUSHINGS – BRONZE PLATED – METRIC						
L1 LENGTH +0.00 -0.76	INSIDE DIAMETER					
	20mm	25mm	30mm	40mm	50mm	60mm
25.00	LBBM-20-x-25	LBBM-25-x-25	LBBM-30-x-25	LBBM-40-x-25		
30.00	LBBM-20-x-30	LBBM-25-x-30	LBBM-30-x-30	LBBM-40-x-30	LBBM-50-x-30	LBBM-60-x-30
40.00	LBBM-20-x-40	LBBM-25-x-40	LBBM-30-x-40	LBBM-40-x-40	LBBM-50-x-40	LBBM-60-x-40
50.00	LBBM-20-x-50	LBBM-25-x-50	LBBM-30-x-50	LBBM-40-x-50	LBBM-50-x-50	LBBM-60-x-50
65.00	LBBM-20-x-65	LBBM-25-x-65	LBBM-30-x-65	LBBM-40-x-65	LBBM-50-x-65	LBBM-60-x-65
80.00	LBBM-20-x-80	LBBM-25-x-80	LBBM-30-x-80	LBBM-40-x-80	LBBM-50-x-80	LBBM-60-x-80
100.00	LBBM-20-x-100	LBBM-25-x-100	LBBM-30-x-100	LBBM-40-x-100	LBBM-50-x-100	LBBM-60-x-100
120.00	LBBM-20-x-120	LBBM-25-x-120	LBBM-30-x-120	LBBM-40-x-120	LBBM-50-x-120	LBBM-60-x-120
140.00		LBBM-25-x-140	LBBM-30-x-140	LBBM-40-x-140	LBBM-50-x-140	LBBM-60-x-140
150.00		LBBM-25-x-150	LBBM-30-x-150	LBBM-40-x-150	LBBM-50-x-150	LBBM-60-x-150





Lamina Components

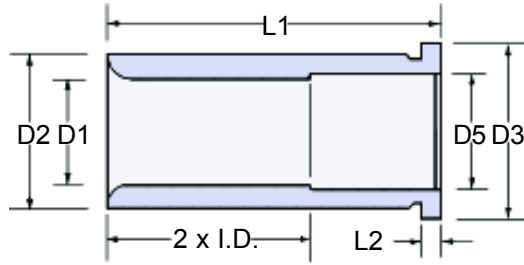

GENERAL DIMENSIONS					
Nom. I.D.	D1 +0.0005 -0.0000	D2 +0.0005 -0.0000	D3 +0.000 -0.005	D5 +0.015 -0.000	L2 +0.000 -0.005
3/4	.7505	1.1255	1.302	.780	.187
7/8	.8755	1.2505	1.427	.905	.187
1	1.0005	1.3755	1.552	1.031	.187
1-1/4	1.2505	1.6255	1.802	1.280	.187
1-1/2	1.5005	2.0005	2.177	1.531	.187
2	2.0005	2.5005	2.677	2.031	.187
2-1/2	2.5005	3.2505	3.427	2.531	.187
3	3.0005	3.7505	3.990	3.031	.500

SHOULDER BUSHING – SOLID STEEL – INCH

L LENGTH	d1(INSIDE DIAMETER) -0.0005 +0.0000							
	.7505	.8755	1.0005	1.2505	1.5005	2.0005	2.5005	3.0005
7/8	HLBB0607	HLBB0707	HLBB0807	HLBB1007	HLBB1207			
1-3/8	HLBB0613	HLBB0713	HLBB0813	HLBB1013	HLBB1213	HLBB1613	HLBB2013	
1-7/8	HLBB0617	HLBB0717	HLBB0817	HLBB1017	HLBB1217	HLBB1617	HLBB2017	
2-3/8	HLBB0623	HLBB0723	HLBB0823	HLBB1023	HLBB1223	HLBB1623	HLBB2023	
2-7/8	HLBB0627	HLBB0727	HLBB0827	HLBB1027	HLBB1227	HLBB1627	HLBB2027	
3-3/8	HLBB0633	HLBB0733	HLBB0833	HLBB1033	HLBB1233	HLBB1633	HLBB2033	
3-7/8	HLBB0637	HLBB0737	HLBB0837	HLBB1037	HLBB1237	HLBB1637	HLBB2037	HLBB2437
4-3/8	HLBB0643	HLBB0743	HLBB0843	HLBB1043	HLBB1243	HLBB1643	HLBB2043	
4-7/8	HLBB0647	HLBB0747	HLBB0847	HLBB1047	HLBB1247	HLBB1647	HLBB2047	HLBB2447
5-7/8	HLBB0657	HLBB0757	HLBB0857	HLBB1057	HLBB1257	HLBB1657	HLBB2057	HLBB2457
7-7/8								HLBB2477

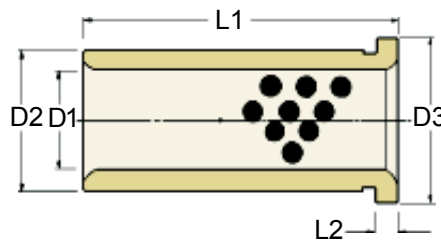

GENERAL DIMENSIONS				
Nom I.D.	D1 +0.0005 -0.0000	D2 +0.0005 -0.0000	D3 +0.000 -0.005	L2 +0.000 -0.005
3/4	.7505	1.1255	1.302	.187
7/8	.8755	1.2505	1.427	.187
1	1.0005	1.3755	1.552	.187
1-1/4	1.2505	1.6255	1.802	.187
1-1/2	1.5005	2.0005	2.177	.187
2	2.0005	2.5005	2.677	.187
2-1/2	2.5005	3.2505	3.427	.187
3	3.0005	3.7505	3.990	.500

SHOULDER BUSHINGS – SELF-LUBRICATING – INCH

L1 LENGTH -.031-.062	INSIDE DIAMETER							
	3/4	7/8	1	1-1/4	1-1/2	2	2-1/2	3
7/8	BGLB0607	BGLB0707	BGLB0807	BGLB1007	BGLB1207			
1-3/8	BGLB0613	BGLB0713	BGLB0813	BGLB1013	BGLB1213	BGLB1613	BGLB2013	
1-7/8	BGLB0617	BGLB0717	BGLB0817	BGLB1017	BGLB1217	BGLB1617	BGLB2017	
2-3/8	BGLB0623	BGLB0723	BGLB0823	BGLB1023	BGLB1223	BGLB1623	BGLB2023	
2-7/8	BGLB0627	BGLB0727	BGLB0827	BGLB1027	BGLB1227	BGLB1627	BGLB2027	
3-3/8	BGLB0633	BGLB0733	BGLB0833	BGLB1033	BGLB1233	BGLB1633	BGLB2033	
3-7/8	BGLB0637	BGLB0737	BGLB0837	BGLB1037	BGLB1237	BGLB1637	BGLB2037	BGLB2437
4-3/8	BGLB0643	BGLB0743	BGLB0843	BGLB1043	BGLB1243	BGLB1643	BGLB2043	
4-7/8	BGLB0647	BGLB0747	BGLB0847	BGLB1047	BGLB1247	BGLB1647	BGLB2047	BGLB2447
5-7/8	BGLB0657	BGLB0757	BGLB0857	BGLB1057	BGLB1257	BGLB1657	BGLB2057	BGLB2457
7-7/8								BGLB2477



Lamina Components

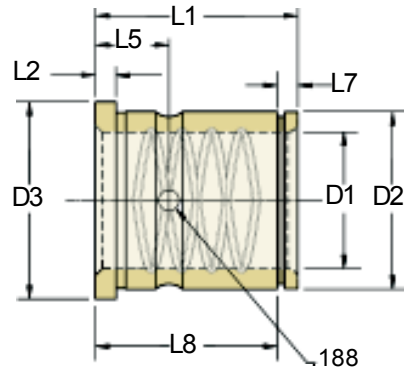

- Lubrication ring with lubrication hole
- Press Fit Diameter ground to size
- Radii to serve as lead
- I.D. Oversize to accommodate expansion

SHOULDER BUSHINGS – SOLID BRONZE –INCH

PART NUMBER	Nom ID.	D1 +.0005 -.0000	D2 +.0005 -.0000	D3 +.000 -.015	L1 -.031 -.062	L2 +.000 -.005	L5 ±.01	L7	L8	PART NUMBER	Nom ID.	D1 +.0005 -.0000	D2 +.0005 -.0000	D3 +.000 -.015	L1 -.031 -.062	L2 +.000 -.005	L5 ±.01	L7	L8			
BFB0607	3/4"	.7505	1.1255	1.302	7/8	.187	.187	.187	0.657	BFB1207	1-1/2"	1.5005	2.0005	2.177	7/8	.187	.187	.187	0.657			
BFB0613					1-3/8				1.157	BFB1213					1-3/8				1.157			
BFB0617					1-7/8				1.657	BFB1217					1-7/8				1.657			
BFB0623					2-3/8				2.157	BFB1223					2-3/8				2.157			
BFB0627					2-7/8				2.657	BFB1227					2-7/8				2.657			
BFB0633					3-3/8				3.157	BFB1233					3-3/8				3.157			
BFB0637					3-7/8				3.657	BFB1237					3-7/8				3.657			
BFB0643					4-3/8				4.157	BFB1243					4-3/8				4.157			
BFB0647					4-7/8				4.657	BFB1247					4-7/8				4.657			
BFB0657					5-7/8				5.657	BFB1257					5-7/8				5.657			
BFB0707					7/8"				.8755	1.2505					1.427				7/8	.187	.187	.187
BFB0713	1-3/8	1.157	BFB1617	1-7/8		1.657																
BFB0717	1-7/8	1.657	BFB1623	2-3/8		2.157																
BFB0723	2-3/8	2.157	BFB1627	2-7/8		2.657																
BFB0727	2-7/8	2.657	BFB1633	3-3/8		3.157																
BFB0733	3-3/8	3.157	BFB1637	3-7/8		3.657																
BFB0737	3-7/8	3.657	BFB1643	4-3/8		4.157																
BFB0743	4-3/8	4.157	BFB1647	4-7/8		4.657																
BFB0747	4-7/8	4.657	BFB1657	5-7/8		5.657																
BFB0757	5-7/8	5.657	BFB2013	1-3/8		.56	.187	.187			1.157											
BFB0807	7/8	0.657	BFB2017	1-7/8							1.657											
BFB0813	1-3/8	1.157	BFB2023	2-3/8	2.157																	
BFB0817	1-7/8	1.657	BFB2027	2-7/8	2.657																	
BFB0823	2-3/8	2.157	BFB2033	3-3/8	3.157																	
BFB0827	2-7/8	2.657	BFB2037	3-7/8	3.657																	
BFB0833	3-3/8	3.157	BFB2043	4-3/8	4.157																	
BFB0837	3-7/8	3.657	BFB2047	4-7/8	4.657																	
BFB0843	4-3/8	4.157	BFB2057	5-7/8	5.657																	
BFB0847	4-7/8	4.657	BFB2437	3-7/8	.500				1.56	.500	3.344											
BFB0857	5-7/8	5.657	BFB2447	4-7/8							4.344											
BFB1007	7/8	0.657	BFB2457	5-7/8		5.344																
BFB1013	1-1/4"	1.2505	1.6255	1.802	7/8	.187	.187	.187	0.657	BFB2477	3"	3.0005	3.7505	3.990	7-7/8	.500	1.56	.500	7.344			
BFB1017					1-3/8				1.157	BFB2477					7-7/8				7.344			
BFB1017					1-7/8				1.657													
BFB1023					2-3/8				2.157													
BFB1027					2-7/8				2.657													
BFB1033					3-3/8				3.157													
BFB1037					3-7/8				3.657													
BFB1043					4-3/8				4.157													
BFB1047					4-7/8				4.657													
BFB1057					5-7/8				5.657													

RETAINING RINGS – (OPTIONAL)

PART NUMBER	NOMINAL DIAMETER	WIDTH	FREE I.D.
MSC100019	3/4	0.050	1.041
MSC100020	7/8	0.050	1.156
MSC100021	1	0.050	1.272
MSC100022	1-1/4	0.062	1.503
MSC100023	1-1/2	0.062	1.850
MSC100024	2	0.078	2.313
MSC100025	2-1/2	0.093	3.006
MSC100026	3	0.109	3.468

Retaining rings are used for slip fit applications.





Lamina Components

Bronze plated bushings offer the lubricity of bronze and the strength of steel in one complete component.

STRAIGHT BUSHING – BRONZE PLATED – INCH				
PART NUMBER	Nom. I.D.	D1	D2	L1 LENGTH
		+0.0005 –0.0000		–0.031 –0.062
STB-06-07 STB-06-13	3/4	.7505	1.1255	.875 1.375
STB-07-13	7/8	.8755	1.2505	1.375
STB-08-13	1	1.0005	1.3755	1.375
STB-10-13 STB-10-17	1-1/4	1.2505	1.6255	1.375 1.875
STB-12-13 STB-12-17	1-1/2	1.5005	2.0005	1.375 1.875
STB-16-37	2	2.0005	2.5005	3.875
STB-20-47	2-1/2	2.5005	3.2505	4.875
STB-24-47	3	3.0005	3.7505	4.875

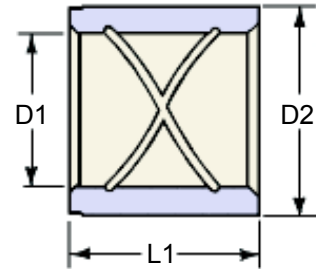
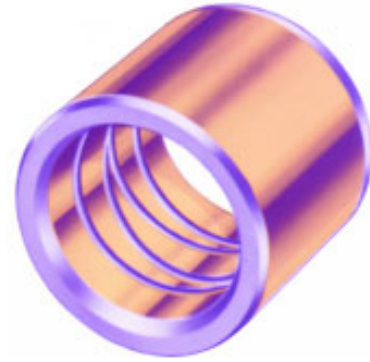

Bronze plated and solid steel bushings should be lubricated with high-pressure lithium grease.

Solid steel bushings are economical in short run applications.

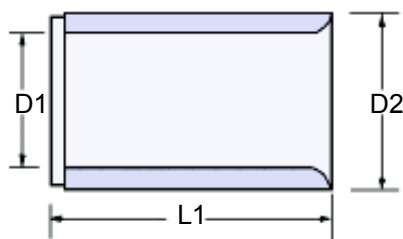

STRAIGHT BUSHINGS – SOLID STEEL – INCH				
PART NUMBER	Nom. I.D.	D1 I.D.	D2 O.D.	L1 LENGTH
		+0.0005 –0.0000		–0.031 –0.062
HSTB0607 HSTB0613	3/4	.7505	1.1255	.875 1.375
HSTB0713	7/8	.8755	1.2505	1.375
HSTB0813	1	1.0005	1.3755	1.375
HSTB1013 HSTB1017	1-1/4	1.2505	1.6255	1.375 1.875
HSTB1213 HSTB1217	1-1/2	1.5005	2.0005	1.375 1.875
HSTB1637	2	2.0005	2.5005	3.875
HSTB2047	2-1/2	2.5005	3.2505	4.875



Lamina Components

STRAIGHT BUSHINGS – SELF-LUBRICATING – INCH				
PART NUMBER	Nom. I.D.	D1 I.D.	D2 O.D.	L1 LENGTH
		+0.0005 –0.0000		+0.000 –0.030
BGST0607	3/4	0.7505	1.1255	.875
BGST0611				1.375
BGST0612				1.500
BGST0710	7/8	0.8755	1.2505	1.250
BGST0711				1.375
BGST0712				1.500
BGST0810	1	1.0005	1.3755	1.250
BGST0811				1.375
BGST0812				1.500
BGST0814				1.750
BGST0816				2.000
BGST0824				3.000
BGST1010	1-1/4	1.2505	1.6255	1.250
BGST1011				1.375
BGST1012				1.500
BGST1014				1.750
BGST1015				1.875
BGST1016				2.000
BGST1024	3.000			
BGST1210	1-1/2	1.5005	2.0005	1.250
BGST1211				1.375
BGST1212				1.500
BGST1214				1.750
BGST1215				1.875
BGST1216				2.000
BGST1224	3.000			
BGST1410	1-3/4	1.7505	2.2505	1.250
BGST1412				1.500
BGST1414				1.750
BGST1416				2.000
BGST1420				2.500
BGST1424				3.000
BGST1428	3.500			
BGST1432	4.000			
BGST1610	2	2.0005	2.5005	1.250
BGST1612				1.500
BGST1616				2.000
BGST1620				2.500
BGST1624				3.000
BGST1631				3.875
BGST1639	4.875			
BGST1812	2-1/4	2.2505	2.7505	1.500
BGST1816				2.000
BGST1820				2.500
BGST1824				3.000
BGST2012	2-1/2	2.5005	3.2505	1.500
BGST2016				2.000
BGST2024				3.000
BGST2039				4.875
BGST2416	3	3.0005	3.7505	2.000
BGST2420				2.500
BGST2424				3.000
BGST2428				3.500
BGST2439				4.875

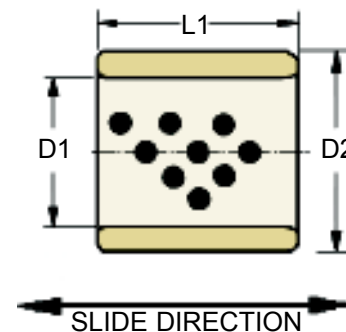

- Self Lubricating
- Consistent quality control
- Resists abrasion
- Excellent wear characteristics

Oil-impregnated graphite plugs cover 20-30% of the wear surface, providing a self-lubricating film of graphite on the wear surface.

Lamina recommends using a light machine oil at time of installation. Regular lubrication will enhance the life of self-lubricating bushings featuring oil-impregnated graphite plugs.



Solid bronze bushings are the first choice among many plastics injection molders.

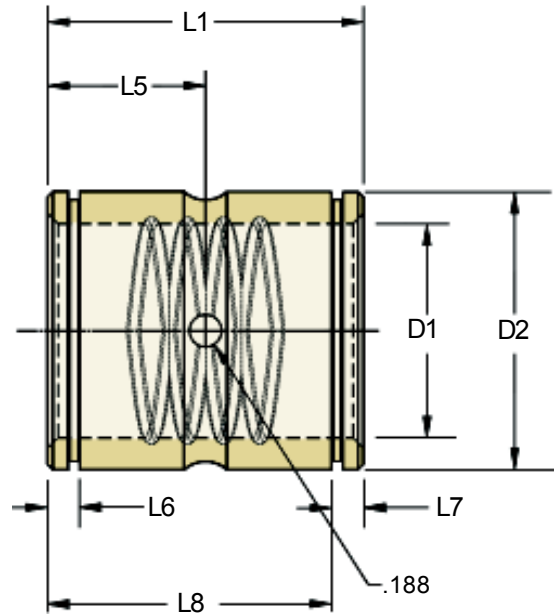

STRAIGHT BUSHINGS – SOLID BRONZE – INCH								
PART NUMBER	Nom. I.D.	D1 I.D.	D2 O.D.	L1 LENGTH	L5	L6	L7	L8
		+0.0005 -0.0000		-0.031 -0.062	±0.010	±0.005	Ref.	±0.010
BSB0607	3/4	0.7500	1.1255	.875	0.92	.187	.187	0.657
BSB0613				1.375				1.157
BSB0617				1.875				1.357
BSB0713	7/8	0.8750	1.2505	1.375	0.67			1.157
BSB0813	1	1.0000	1.3755	1.375	0.67			1.157
BSB0817				1.875	0.92			1.357
BSB0827				2.875	1.42			2.657
BSB1013	1-1/4	1.2500	1.6255	1.375	0.67			1.157
BSB1017				1.875	0.92			1.657
BSB1027				2.875	1.42			2.657
BSB1213	1-1/2	1.5000	2.0005	1.375	0.67	1.157		
BSB1217				1.875	0.92	1.657		
BSB1227				2.875	1.42	2.657		
BSB1637	2	2.0000	2.5005	3.875	1.92	3.657		
BSB2047	2-1/2	2.5000	3.2505	4.875	2.42	4.657		
BSB2447	3	3.0000	3.7505	4.875	2.42	.5	.5	4.344

Retaining rings are used for slip fit applications.



RETAINING RINGS – (OPTIONAL)			
PART NUMBER	NOMINAL DIAMETER	WIDTH	FREE I.D.
MSC100019	3/4	0.050	1.041
MSC100020	7/8	0.050	1.156
MSC100021	1	0.050	1.272
MSC100022	1-1/4	0.062	1.503
MSC100023	1-1/2	0.062	1.850
MSC100024	2	0.078	2.313
MSC100025	2-1/2	0.093	3.006
MSC100026	3	0.109	3.468



EJECTOR BUSHINGS – BRONZE PLATED – INCH									
PART NUMBER	Nom. I.D.	D1 +.0005 -.0000	D2 +.0005 -.0000	D3 +.000 -.010	D4 +.000 -.001	L1 +.000 -.030	L2 +.000 -.005	L3 +.000 -.015	L5 ±.005
ELB-750	3/4	.7510	1.1255	1.302	1.124	1.500	.187	1.000	.560
ELB-875	7/8	.8760	1.2505	1.427	1.249	1.500		1.000	.560
ELB-100	1	1.0010	1.3755	1.552	1.374	1.750		1.120	.620
ELB-125	1-1/4	1.2510	1.6255	1.802	1.624	1.750		1.120	.620
ELB-150	1-1/2	1.5010	2.0005	2.177	1.999	1.750		1.120	.620
ELB-200	2	2.0010	2.5005	2.687	2.499	2.250		1.620	.800

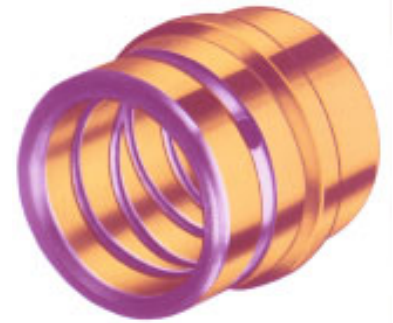

EJECTOR BUSHINGS – BRONZE PLATED – METRIC									
PART NUMBER	Nom. I.D.	D1 +0.013 -0.000	D2 +0.013 -0.000	D3 +0.00 -0.13	D4 +0.000 -0.026	L1 +0.00 -0.76	L2 +0.00 -0.26	L3 +0.00 -0.38	L5 ±0.13
EJM-20	20	20.063	26.013	28.00	26.00	37.00	5.00	25.00	15.00
EJM-25	25	25.063	32.013	35.00	32.00	45.00		29.00	16.00
EJM-30	30	30.063	38.013	41.00	38.00	45.00		29.00	16.00

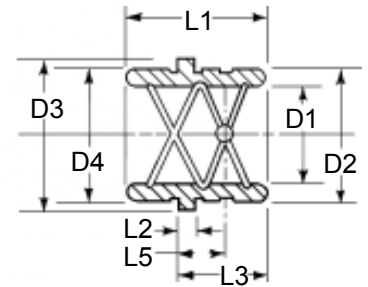

FEATURES:

- Lubrication ring with lubrication hole
- Press Fit Diameter ground to size
- Opposite end ground for ejector plate removal
- Lamina Bronze plated I.D.
- Radii to serve as lead
- I.D. Oversize to accommodate expansion
- Plating thickness .004 - .005 per side

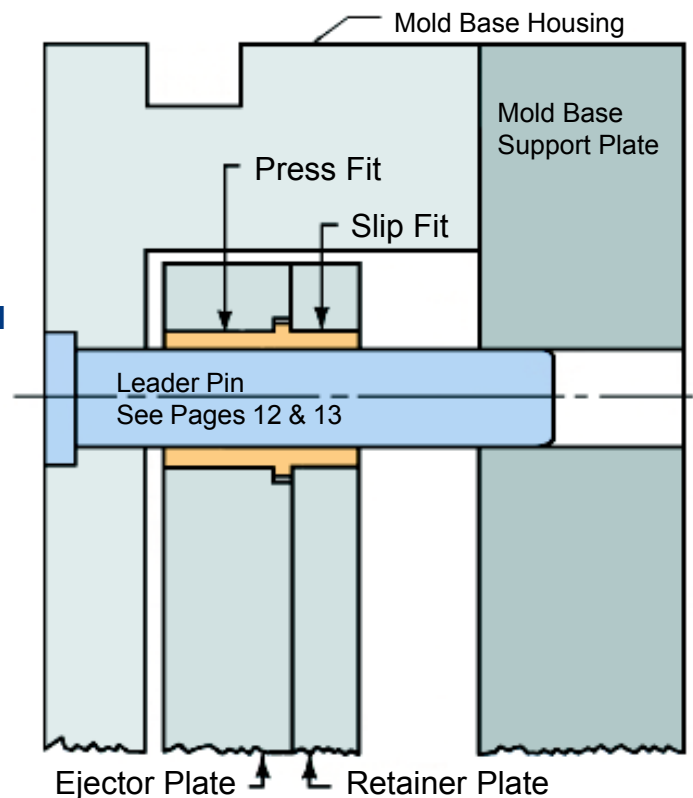

- Self Lubricating
- Consistent quality control
- Resists abrasion
- Excellent wear characteristics



EJECTOR BUSHINGS – SELF-LUBRICATING – INCH								
PART NUMBER	Nom. I.D.	D1	D2	D3	D4	L1	L2	L3
		+0.005 -0.000	+0.005 -0.000	+0.00 -0.010	+0.00 -0.001	+0.00 -0.030	+0.00 -0.005	+0.00 -0.015
BGEL0612	3/4	0.7510	1.1255	1.302	1.124	1.50	.187	1.000
BGEL0712	7/8	0.8760	1.2505	1.427	1.249	1.50		1.000
BGEL0814	1	1.0010	1.3755	1.552	1.374	1.75		1.120
BGEL0816						2.00		1.620
BGEL1014	1-1/4	1.2510	1.6255	1.802	1.624	1.75		1.120
BGEL1020						2.50		1.870
BGEL1214	1-1/2	1.5010	2.0005	2.177	1.999	1.75		1.120
BGEL1220						2.50		1.870
BGEL1618	2	2.0010	2.5005	2.687	2.499	2.25		1.620

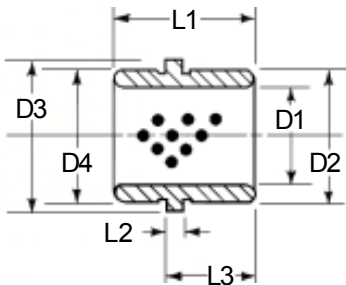

EJECTOR BUSHINGS – SELF-LUBRICATING – METRIC								
PART NUMBER	Nom. I.D.	D1	D2	D3	D4	L1	L2	L3
		+0.013 -0.000	+0.013 -0.000	+0.00 -0.13	+0.000 -0.026	+0.00 -0.76	+0.00 -0.26	+0.00 -0.38
BGELM2037	20	20.063	26.013	28.00	26.00	37.00	5.00	25.00
BGELM2545	25	25.063	32.013	35.00	32.00	45.00		29.00
BGELM3045	30	30.063	38.013	41.00	38.00	45.00		29.00

Oil-impregnated graphite plugs cover 20-30% of the wear surface, providing a self-lubricating film of graphite on the wear surface.



Lamina Components

- Lubrication ring with lubrication hole
- Press Fit Diameter ground to size
- Opposite end ground for ejector plate removal
- Radii to serve as lead
- I.D. Oversize to accommodate expansion

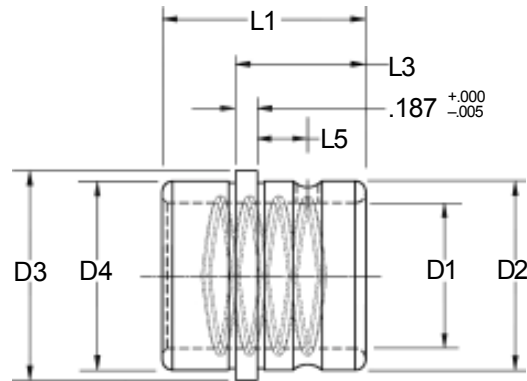

EJECTOR BUSHINGS – SOLID BRONZE – INCH								
PART NUMBER	Nom. I.D.	D1 +.0005 -.0000	D2 +.0005 -.0000	D3 +.000 -.015	D4 +.000 -.001	L1 +.000 -.030	L3 +.000 -.015	L5 ±.01
BEB0612	3/4	.7510	1.1255	1.302	1.124	1.500	1.000	.56
BEB0712	7/8	.8760	1.2505	1.427	1.249	1.500	1.000	.56
BEB0814	1	1.0010	1.3755	1.552	1.374	1.750	1.120	.62
BEB1014	1-1/4	1.2510	1.6255	1.802	1.624	1.750	1.120	.62
BEB1214	1-1/2	1.5010	2.0005	2.177	1.999	1.750	1.120	.62
BEB1618	2	2.0010	2.5005	2.687	2.499	2.250	1.620	.80

Lamina wear strips and gibs complement our line of mold components. See our Sliding Components Catalog.

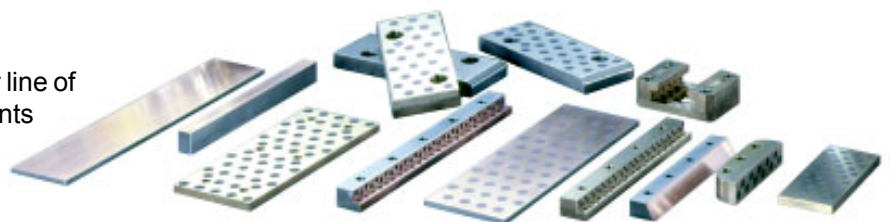



Lamina Components

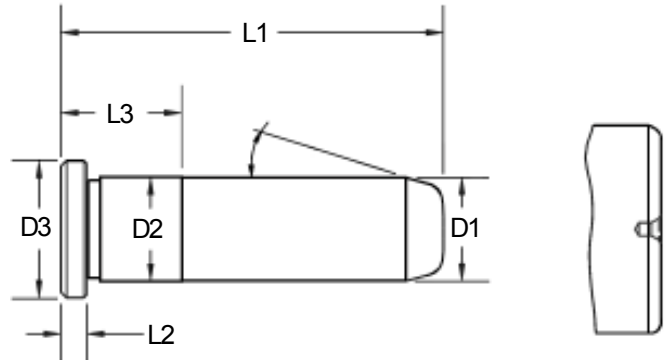

3/4" diameter – 1-1/2" diameter have taper length of 1/4"
 2" & 2-1/2" have taper length of 3/8"
 3" Pins have radius

Not all pins are ground on centers.

GENERAL DIMENSIONS				
NOM PIN DIA	D1 +.0000 -.0005	D2 +.0005 -.0000	D3 +.000 -.010	L2 +.000 -.005
3/4	.7490	.7510	.990	.187
7/8	.8740	.8760	1.115	.250
1	.9990	1.0010	1.240	.250
1-1/4	1.2490	1.2510	1.490	.312
1-1/2	1.4990	1.5010	1.740	.312
2	1.9990	2.0010	2.240	.312
2-1/2	2.4990	2.5010	2.740	.312
3	2.9990	3.0010	3.365	.500

Precision-ground steel construction. Lamina has produced hundreds of thousands of these pins. No finer quality will be found anywhere.

LEADER PINS – INCH																
L1 OVERALL L LENGTH	NOMINAL DIA. 3/4"		NOMINAL DIA. 7/8"		NOMINAL DIA. 1"		NOMINAL DIA. 1-1/4"		NOMINAL DIA. 1-1/2"		NOMINAL DIA. 2"		NOMINAL DIA. 2-1/2"		NOMINAL DIA. 3"	
	PART NUMBER	L3	PART NUMBER	L3	PART NUMBER	L3	PART NUMBER	L3	PART NUMBER	L3	PART NUMBER	L3	PART NUMBER	L3	PART NUMBER	L3
1-3/4	06-16-LP	7/8	07-16-LP	7/8	08-16-LP	7/8										
2-1/4	06-22-LP	7/8	07-22-LP	7/8	08-22-LP	7/8										
2-3/4	06-26-LP	7/8	07-26-LP	7/8	08-26-LP	7/8	10-26-LP	7/8								
3-1/4	06-32-LP	7/8	07-32-LP	7/8	08-32-LP	7/8	10-32-LP	7/8								
3-3/4	06-36-LP	7/8	07-36-LP	7/8	08-36-LP	7/8	10-36-LP	7/8	12-36-LP	1-3/8						
4-1/4	06-42-LP	1-3/8	07-42-LP	1-3/8	08-42-LP	1-3/8	10-42-LP	7/8	12-42-LP	1-3/8						
4-3/4	06-46-LP	1-3/8	07-46-LP	1-3/8	08-46-LP	1-3/8	10-46-LP	1-3/8	12-46-LP	1-3/8						
5-1/4	06-52-LP	1-3/8	07-52-LP	1-3/8	08-52-LP	1-3/8	10-52-LP	1-3/8	12-52-LP	1-3/8						
5-3/4	06-56-LP	1-7/8	07-56-LP	1-3/8	08-56-LP	1-3/8	10-56-LP	1-3/8	12-56-LP	1-3/8	16-56-LP	1-7/8	20-56-LP	2-3/8		
6-1/4	06-62-LP	1-7/8	07-62-LP	1-7/8	08-62-LP	1-3/8	10-62-LP	1-3/8	12-62-LP	1-3/8						
6-3/4	06-66-LP	1-7/8	07-66-LP	1-7/8	08-66-LP	1-7/8	10-66-LP	1-7/8	12-66-LP	1-3/8	16-66-LP	1-7/8	20-66-LP	2-3/8		
7-1/4	06-72-LP	1-7/8	07-72-LP	1-7/8	08-72-LP	1-7/8	10-72-LP	1-7/8								
7-3/4	06-76-LP	1-7/8	07-76-LP	1-7/8	08-76-LP	1-7/8	10-76-LP	1-7/8	12-76-LP	1-7/8	16-76-LP	1-7/8	20-76-LP	2-3/8		
8-1/4			07-82-LP	1-7/8	08-82-LP	1-7/8	10-82-LP	1-7/8								
8-3/4			07-86-LP	1-7/8	08-86-LP	1-7/8	10-86-LP	1-7/8	12-86-LP	1-7/8	16-86-LP	1-7/8	20-86-LP	2-3/8	24-86-LP	2-7/8
9-1/4	06-92-LP	1-7/8	07-92-LP	1-7/8	08-92-LP	1-7/8	10-92-LP	1-7/8								
9-3/4					08-96-LP	1-7/8	10-96-LP	1-7/8	12-96-LP	1-7/8	16-96-LP	1-7/8	20-96-LP	2-3/8		
10-1/4					08-102-LP	1-7/8	10-102-LP	1-7/8								
10-3/4			07-106-LP	1-7/8	08-106-LP	1-7/8	10-106-LP	1-7/8	12-106-LP	1-7/8	16-106-LP	1-7/8	20-106-LP	2-3/8	24-106-LP	2-7/8
11-1/4					08-112-LP	1-7/8	10-112-LP	1-7/8								
11-3/4					08-116-LP	1-7/8	10-116-LP	1-7/8	12-116-LP	1-7/8	16-116-LP	1-7/8	20-116-LP	2-3/8		
12-1/4			07-122-LP	1-7/8	08-122-LP	1-7/8	10-122-LP	1-7/8								
12-3/4							10-126-LP	1-7/8	12-126-LP	1-7/8	16-126-LP	1-7/8	20-126-LP	2-3/8	24-126-LP	2-7/8
13-3/4							10-136-LP	1-7/8	12-136-LP	1-7/8	16-136-LP	1-7/8	20-136-LP	2-3/8		
14-3/4							10-146-LP	1-7/8	12-146-LP	1-7/8	16-146-LP	1-7/8	20-146-LP	2-3/8	24-146-LP	2-7/8
15-3/4							10-156-LP	1-7/8	12-156-LP	1-7/8	16-156-LP	1-7/8	20-156-LP	2-3/8		
16-3/4											16-166-LP	1-7/8	20-166-LP	2-3/8	24-166-LP	2-7/8
18-3/4											16-186-LP	1-7/8	20-186-LP	2-3/8	24-186-LP	2-7/8



Lamina Components

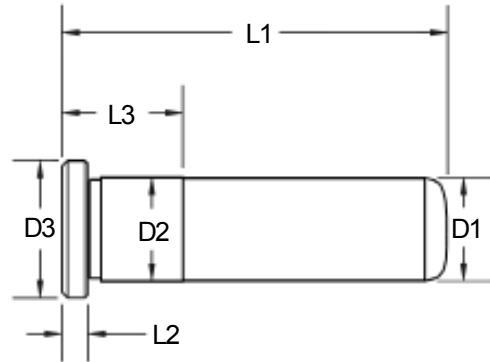

20mm through 60mm
Not all pins are ground on centers.

GENERAL DIMENSIONS				
NOM PIN DIA	D1	D2	D3	L2
20	+0.000 -0.013	+0.013 -0.000	+0.00 -0.26	+0.00 -0.05
25	19.975	20.025	25.00	5.00
30	24.975	25.025	31.00	6.00
40	29.975	30.025	36.00	8.00
50	39.975	40.025	46.00	8.00
60	49.975	50.025	56.00	8.00

LEADER PINS – METRIC												
L1 OVERALL LENGTH	NOMINAL DIA. 20mm		NOMINAL DIA. 25mm		NOMINAL DIA. 30mm		NOMINAL DIA. 40mm		NOMINAL DIA. 50mm		NOMINAL DIA. 60mm	
	PART NUMBER	L3	PART NUMBER	L3	PART NUMBER	L3	PART NUMBER	L3	PART NUMBER	L3	PART NUMBER	L3
50mm	MLP-20-x-50	25mm	MLP-25-x-50	25mm								
60mm	MLP-20-x-60	25mm	MLP-25-x-60	25mm								
70mm	MLP-20-x-70	25mm	MLP-25-x-70	25mm	MLP-30-x-70	25mm						
80mm	MLP-20-x-80	25mm	MLP-25-x-80	25mm	MLP-30-x-80	25mm						
90mm	MLP-20-x-90	25mm	MLP-25-x-90	25mm	MLP-30-x-90	25mm	MLP-40-x-90	35mm				
100mm	MLP-20-x-100	25mm	MLP-25-x-100	25mm	MLP-30-x-100	25mm	MLP-40-x-100	35mm				
120mm	MLP-20-x-120	35mm	MLP-25-x-120	35mm	MLP-30-x-120	35mm	MLP-40-x-120	35mm				
140mm	MLP-20-x-140	35mm	MLP-25-x-140	35mm	MLP-30-x-140	35mm	MLP-40-x-140	35mm				
150mm									MLP-50-x-150	45mm	MLP-60-x-150	60mm
160mm	MLP-20-x-160	45mm	MLP-25-x-160	35mm	MLP-30-x-160	35mm	MLP-40-x-160	35mm				
175mm									MLP-50-x-175	45mm	MLP-60-x-175	60mm
180mm	MLP-20-x-180	45mm	MLP-25-x-180	45mm	MLP-30-x-180	45mm	MLP-40-x-180	45mm				
200mm	MLP-20-x-200	45mm	MLP-25-x-200	45mm	MLP-30-x-200	45mm	MLP-40-x-200	45mm	MLP-50-x-200	45mm	MLP-60-x-200	60mm
220mm	MLP-20-x-220	45mm	MLP-25-x-220	45mm	MLP-30-x-220	45mm	MLP-40-x-220	45mm				
225mm									MLP-50-x-225	45mm	MLP-60-x-225	60mm
240mm	MLP-20-x-240	45mm	MLP-25-x-240	45mm	MLP-30-x-240	45mm	MLP-40-x-240	45mm				
250mm									MLP-50-x-250	45mm	MLP-60-x-250	60mm
260mm			MLP-25-x-260	45mm	MLP-30-x-260	45mm	MLP-40-x-260	45mm				
275mm									MLP-50-x-275	45m	MLP-60-x-275	60mm
280mm			MLP-25-x-280	45mm	MLP-30-x-280	45mm	MLP-40-x-280	45mm				
300mm			MLP-25-x-300	45mm	MLP-30-x-300	45mm	MLP-40-x-300	45mm	MLP-50-x-300	45mm	MLP-60-x-300	60mm
325mm									MLP-50-x-325	45mm	MLP-60-x-325	60mm
350mm									MLP-50-x-350	45mm	MLP-60-x-350	60mm
375mm									MLP-50-x-375	45mm	MLP-60-x-375	60mm
400mm									MLP-50-x-400	45mm	MLP-60-x-400	60mm





Lamina Components

CONVERSION TABLES

INCHES TO MILLIMETERS .03937" = 1mm

Inches	mm	Inches	mm	Inches	mm	Inches	mm			
0.001	0.0254	11/64	0.1718	4.3660	0.4600	11.684	3/4	0.7500	19.050	
0.002	0.0508	3/16	0.1875	4.7630	15/32	0.4687	11.906	49/64	0.7656	19.447
0.003	0.0762		0.1900	4.8260	31/64	0.4843	12.303		0.7700	19.558
0.004	0.1016	13/64	0.2031	5.1590		0.4900	12.446	25/32	0.7810	19.844
0.005	0.1270	7/32	0.2187	5.5560	1/2	0.5000	12.700	51/64	0.7968	20.241
0.006	0.1524	15/64	0.2343	5.9630		0.5100	12.954		0.8000	20.320
0.007	0.1778		0.2400	6.0960	33/64	0.5156	13.097	13/16	0.8125	20.638
0.008	0.2032		0.250	6.3500		0.5200	13.208		0.8200	20.828
0.009	0.2286	17/64	0.2656	6.7470	17/32	0.5312	13.494	53/64	0.8280	21.034
0.010	0.2540		0.2700	6.8580		0.5400	13.716		0.8400	21.336
1/64	0.0156	9/32	0.2812	7.1440	35/64	0.5460	13.891	27/32	0.8437	21.431
	0.020		0.290	7.3660	9/16	0.5625	14.288		0.8500	21.590
	0.030	19/64	0.2968	7.5410	37/64	0.5780	14.684	55/64	0.8594	21.828
1/32	0.0312	5/16	0.3125	7.9380	19/32	0.5937	15.081		0.8700	22.098
	0.040		0.3200	8.1280		0.6000	15.240	7/8	0.8750	22.225
3/64	0.0469	21/64	0.3280	8.3340	39/64	0.6090	15.478		0.8800	22.352
	0.050	11/32	0.3437	8.7310		0.6200	15.748		0.8900	22.606
	0.060		0.350	8.8900	5/8	0.6250	15.875	57/64	0.8906	22.622
1/16	0.0625	23/64	0.3590	9.1280		0.6300	16.002		0.9000	22.860
	0.070		0.3600	9.1440		0.6400	16.256	29/32	0.9060	23.019
5/64	0.0781		0.3700	9.3980	41/64	0.6406	16.272	59/64	0.9218	23.416
	0.080	3/8	0.3750	9.5250		0.6500	16.510		0.9300	23.622
	0.090		0.3800	9.6520	21/32	0.6560	16.669	15/16	0.9375	23.813
3/32	0.094		0.3900	9.9060	43/64	0.6718	17.066		0.9500	24.130
	0.100	25/64	0.3906	9.9220		0.6800	17.272	61/64	0.9530	24.209
7/64	0.1093		0.4000	10.1600	11/16	0.6875	17.463		0.9600	24.384
	0.120	13/32	0.4062	10.3190	45/64	0.7030	17.859	31/32	0.9687	24.606
1/8	0.125	27/64	0.4218	10.7160		0.7100	18.034		0.9800	24.892
9/64	0.1406	7/16	0.4375	11.1130	23/32	0.7187	18.256	63/64	0.9843	25.003
	0.150		0.4500	11.4300		0.7300	18.542		0.9900	25.146
5/32	0.1562	29/64	0.4530	11.5090	47/64	0.7343	18.653		1.0000	25.400

MILLIMETERS TO INCHES .03937" = 1mm

mm	Inches	mm	Inches	mm	Inches	mm	Inches
1	0.03937	26	1.02362	51	2.00787	76	2.99213
2	0.07874	27	1.06299	52	2.04724	77	3.03150
3	0.11811	28	1.10236	53	2.08661	78	3.07087
4	0.15748	29	1.14173	54	2.12598	79	3.11024
5	0.19685	30	1.18110	55	2.16535	80	3.14961
6	0.23622	31	1.22047	56	2.20472	81	3.18898
7	0.27559	32	1.25984	57	2.24409	82	3.22835
8	0.31496	33	1.29921	58	2.28346	83	3.26772
9	0.35433	34	1.33858	59	2.32283	84	3.30709
10	0.39370	35	1.37795	60	2.36220	85	3.34646
11	0.43307	36	1.41732	61	2.40157	86	3.38583
12	0.47244	37	1.45669	62	2.44094	87	3.42520
13	0.51181	38	1.49606	63	2.48031	88	3.46457
14	0.55118	39	1.53543	64	2.51969	89	3.50394
15	0.59055	40	1.57480	65	2.55906	90	3.54331
16	0.62992	41	1.61417	66	2.59843	91	3.58268
17	0.66929	42	1.65354	67	2.63780	92	3.62205
18	0.70866	43	1.69291	68	2.67717	93	3.66142
19	0.74803	44	1.73228	69	2.71654	94	3.70079
20	0.78740	45	1.77165	70	2.75591	95	3.74016
21	0.82677	46	1.81102	71	2.79528	96	3.77953
22	0.86614	47	1.85039	72	2.83465	97	3.81890
23	0.90551	48	1.88976	73	2.87402	98	3.85827
24	0.94488	49	1.92913	74	2.91339	99	3.89764
25	0.98425	50	1.96850	75	2.95276	100	3.93701





LAMINA PRODUCT COLLECTION



DIE COMPONENTS BUSHINGS

- Short Shoulder
- Standard Shoulder
- Long Shoulder
- Extra Long Shoulder
- Precision
- Ball Bearing
- Guide Bar

- Bronze Plated
- Solid Steel
- Solid Bronze
- Self-Lubricating

STEEL GUIDE PINS

- Straight
- Press Fit
- Hollow
- Removable
- Demountable
- Ball Bearing

STRIPPER PINS & BUSHINGS

GUIDE BLOCKS

CORNER GUIDE BLOCKS

KEEPER BLOCKS

WEAR PLATES U & V BLOCKS

CENTER KEYS & GUIDES

GIBS

SPOOL TYPE PAD RETAINERS Inch & Metric

DIE SPRINGS by Associated Spring Raymond

SPRING CAGES

MARSH MELLOW® DIE SPRINGS by Firestone

LAMI-FLEX URETHANE SPRINGS

- Tubes
- Rods
- Sheets & Slabs

DISC SPRINGS by Schnorr

NITROGEN SPRINGS by Kaller

CAMS

- Aerial
- Diemount
- Modular
- Box & Mini

MOLD COMPONENTS BUSHINGS

- Guide
- Ejector
- Straight

LEADER PINS

GIB ASSEMBLIES

WEAR STRIPS Bronze-Plated Bronze Self-Lubricating

WEAR STRIP WAYS

SPECIAL MACHINE COMPONENTS BUSHINGS

- Straight
- Running Fit
- Heat-Treated
- Non-Heat-Treated
- Self-Lubricating

MISCELLANEOUS PRY BARS

HYDRAULIC EQUIPMENT PORTABLE HYDRAULIC DRILLING & TAPPING MACHINES

PORTABLE ELECTRONIC DIE SETTERS

HYDRAULIC MOTORS



Committed to Quality & Customer Satisfaction

Anchor Lamina is committed to be the “customer focused” world-class supplier of choice to the metal-working and plastics forming industry.

We will help our customers to compete globally by providing innovative and value added products and services.

Anchor Lamina Contacts

Lamina Components

38505 Country Club Drive Suite 200
Farmington Hills, MI USA 48331
Tel: 248-489-9122, 800-652-6462; Fax: 248-553-6842
E-Mail: sales@lamina.com

Anchor Die Sets

2590 Ouellette Avenue, Windsor, ON, Canada N8X 1L7
Tel: 519-966-4431, 800-265-5007; Fax: 519-966-3594
E-mail: wineng@anchorlamina.com

1450 Alphonse D-Roy, Montreal, QC, Canada H1W 2K8
Tel: 514-525-5560, 800-263-5560; Fax: 514-525-7835
E-mail: moneng@anchorlamina.com

1200 Lakeshore Road East, Mississauga, ON, Canada L5E 1E9
Tel: 905-274-3448, 800-268-5230; Fax: 905-274-7303
E-mail: miseng@anchorlamina.com

311 Pinebush Road, Cambridge, ON, Canada N1T 1B2
Tel: 519-740-3060, 800-265-7842 (Canada only); Fax: 519-740-8213
E-mail: cameng@anchorlamina.com

95 East Ten Mile Road, Madison Heights, MI USA 48071
Tel: 248-547-5910, 800-543-3790; Fax: 248-547-5918, 800-963-0400
E-mail: wineng@anchorlamina.com

4300 40th Street, S.E., Kentwood, MI USA 49512
Tel: 616-949-8700, 888-526-2467; Fax: 616-949-9580
E-mail: graeng@anchorlamina.com

Reliance Fabrications

95 Lyon Avenue North, Tilbury, ON, Canada N0P 2L0
Tel: 519-682-0470, 800-265-5295; Fax: 519-682-3616
E-mail: releng@anchorlamina.com

www.anchorlamina.com

Preferred Business Partners

Ajacs Die Sales Corp.

Grand Rapids, MI; Tel: 800-968-6868

Dayne Supply

Ontario, CA, Tel: 800-289-6387

R.F. Flood Industrial Supply Corp.

Ivyland, PA, Tel: 800-235-9950

T.R. Goldsmith

Tonawanda, NY, Tel: 800-252-2501

IPSCO Corp.

Attleboro, MA; Tel: 800-229-4044

Manufacturers Equipment & Supply

Flint, MI; Tel: 800-373-2173

Matis Inc.

Chicago Ridge, IL; Tel: 708-425-7100

Matzka Inc.

Warren, MI; Tel: 586-755-6363

Scott Special Tools, Inc.

St. Charles, MO; Tel: 800-638-7277

E.L. Simeth Co., Inc.

Milwaukee, WI; Tel: 800-837-9270

Sup-R-Die

Cleveland, OH; Tel: 800-820-9194

