

VOGEL TOOL & DIE

A Division of T-E-S Tube Equipment, Inc.

Tube & Pipe Fabricating Tools, Dies & Equipment

Product Catalog 2006



Telephone: (630) 562-1400

24-Hour Fax: (630) 562-1500

Website: www.vogeltool.com

E-Mail: info@vogeltool.com

THE ARC-FIT METHOD

The **Arc-Fit method** is a low-cost way of creating accurate notches in tube or pipe ends. The tube is slid onto the tube rest, over the punch. As the punch and punch holder are depressed, the punch notches the bottom wall of the tube. The tube is rotated 180° and the first notch, now on the top of the tube, is visually aligned with the scribe lines on the punch holder. The 2nd notch is made and the tube is ready for welding or brazing. These spring-loaded tools may be powered by most press brakes, ironworkers, punch presses, or Vogel Hand or Hydraulic Presses, see the charts below. Although most popular for 90° T-Joint notches, custom assemblies may be ordered for custom shaped slots, notches with drainholes and more. Please contact the Vogel factory to discuss your specialized notching application.

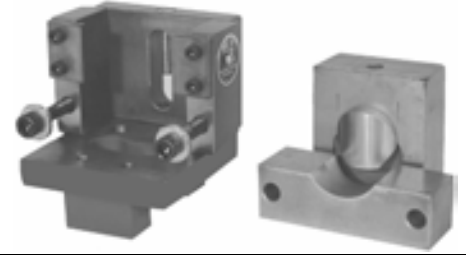

Housing	Capacity				Size		Weight in LBS	Press Requirements			
	Pipe	Tube	Sq.	Wall	L to R	F to B		Shut**	Stroke	Tons	Press
35	2"	2-3/8"	2-3/8"	.218"	4-1/2"	4-1/4"	16	5"	5/8"	8	Hand Press CSP-15-SA CSP-25-SA

**Notes: Punch Press adaptor (used for #35 Housing in your press or Vogel CSP-25-SA) adds 1" to shut height listed above
 #35 Housing includes removable lugs. If removed, the shut height is 4"

An **Arc-Fit Assembly** consists of three pieces, the round punch, square punch holder and rectangular die (tube rest). When worn, (typically 10,000 - 20,000 notches or more), you can send your punch and die to Vogel for sharpening, or simply replace just the worn items.

The **Arc-Fit Housing** holds the punch and die. The charts above and below indicate the maximum capacity of each housing. You may order many assemblies for each housing, or one housing for each assembly to eliminate change over time and increase efficiency. Hardware and springs are included with each housing.

Punch

Punch Holder

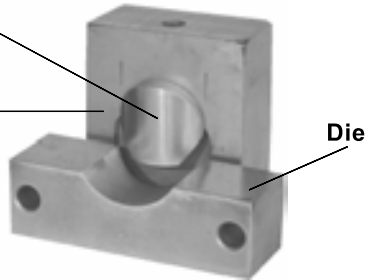

#201A Punch Press Adapter

Use the **#201A Punch Press Adapter** when using the #35 Housing in your press or the Vogel CSP-25-SA Hydraulic Press. This adapter makes mounting easier and insures adequate clearance for slugs.



Housing installed in Adapter

Housing	Capacity				Size		Weight in LBS	Press Requirements			
	Pipe	Tube	Sq.	Wall	L to R	F to B		Shut	Stroke	Tons	Press
75	3"	3-1/2"	3-1/2"	.300"	8"	10"	79	5-1/2" - 6"	1"	15 - 20	CSP-25-SA
125	4"	4-1/2"	4-1/2"	.337"	9"	10"	100	7-1/4" - 8-1/2"	1-1/2" - 2"	30 - 45	Consult Factory
175	5"	5-9/16"	5-9/16"	.375"	10"	12"	140	8-1/4" - 10"	2"	45 - 60	Consult Factory
185	6"	6-5/8"	6-5/8"	.432"	15"	15"	235	8-1/2" - 10"	2"	60 - 80	Consult Factory



#75 Arc-Fit Housing with Assembly
 [Assembly sold separately]



Slot with Drainhole



Square to fit Round



Round to fit Round with Drainhole



Large Tube Notch



Round to fit Round

The Arc-Fit method leaves the side walls of the tube or pipe intact. If your project requires carving through the side walls for a tighter gap-free fit-up see our Arc-Snug tooling (catalog pg. 5).

Arc-Fit **Arc-Snug**



PRESS OPTIONS FOR YOUR VOGEL ARC-FIT

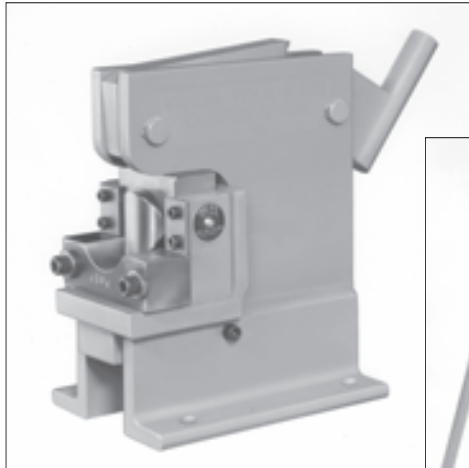

#1400 Hand Press with Housing & Assembly (sold separately)

Our **#1400 Hand Press** is an economical way to power your Arc-Fit Tooling. Only 35 lbs, and portable, you can bench mount, use our convenient Hand Press Stand, or even mount on a work truck for use on the job site. Hand press accepts the #35 Housing only, and is recommended for a maximum of Schedule 40 pipe or 1/8" wall tubing. Base drilled for mounting, you supply 1" standard pipe to extend handle for proper leverage.



#1400 Hand Press with #1405 Hand Press Stand



#1410 Hitch Mount

NEW
Trailer Hitch Mount lets you mount your #1400 Hand Press right on your work truck for job-site use.

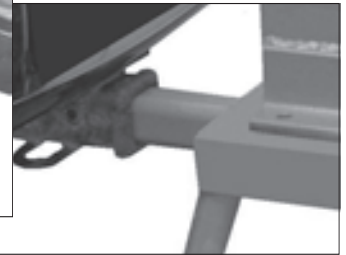

Description		Weight (in lbs.)	Power Specifications			
Model	Accepts the following Vogel Tooling		Power Source	Reservoir	Horsepower	Tonnage
#1400 Hand Press	#35 Housing	35	Manual	N/A	N/A	8
CSP-15-SA	#35 Housing	250	110V , 20 amp	1-1/2 Gallons	1.5	15
CSP-25-SA	#35 Arc-Fit Housing #75 Arc-Fit Housing #75 Arc-Fit Angular Housing (Pg. 5) #400 Arc-Snug Housing (Pg. 5) #PC-75 Picket Fence Tool (Pg. 9) THP / CHP Tube / Channel Pierce Tool (Pg. 9)	275	110V , 20 amp	1-1/2 Gallons	1.5	25
#1405 Stand	#1400 Hand Press	50	N/A	N/A	N/A	N/A
#1410 Hitch Mount	#1400 Hand Press	15	N/A	N/A	N/A	N/A
#1415 Leg Kit	Converts #1410 Hitch Mount to free-standing base	10	N/A	N/A	N/A	N/A
CSP-HT Hand Truck	CSP-15-SA Hydraulic Cage-Style Power Unit CSP-25-SA Hydraulic Cage-Style Power Unit	75	N/A	N/A	N/A	N/A

Vogel offers a selection of **Hydraulic Cage-Style Power Units** to power your Vogel tooling. Each unit features foot-pedal actuation, pressure gauge, two-station pump for faster operation. A three-prong 110V plug (20 amp dedicated circuit recommended) for easy set-up. Add our optional Hand Truck provides for more flexibility & convenience.

ECONO ARC-FIT



The Vogel #25 Econo Arc-Fit is the perfect tool for low-volume notching of light-wall fence industry tubing. This tool is complete with three cutting disks for notching 1-3/8", 1-5/8" & 1-7/8 - 2" fence tubing [1", 1-1/4" & 1-1/2 schedule 10 pipe]. If you need to notch schedule 40 pipe, or require higher productivity, our Arc-Fit tooling described above is the right choice



CSP-15-SA with Assembly on CSP-HT Hand Truck



CSP-15-SA Hydraulic Cage-Style Power Unit

Still notching by hand?
Your existing Arc-Fit tooling will fit these presses. Save time & money, upgrade now!



VOGEL **ARC-TWIN**[®] UNITS

For double notching
90° "T" Joints on pipe
and tubing

For Double Notching Pipe and Tubing

The ARC-TWIN notches both sides of pipe and tubing ends for T-joints with one stroke of the press. There is no deformation, all edges are clean and the "twin notches" form perfect T-joints for welding or brazing. Notching time per tube or pipe end is less than three seconds. The ARC-TWIN Tandem operates exactly like the ARC-TWIN but uses an extra set of Die Inserts to cut notching time in half and double the output. In other words, it double notches two tube or pipe ends at one time. Both die inserts can be the same or different sizes.



Cut away of 90° notch produced by the ARC TWIN Unit (same as ARC FIT but in one stroke)

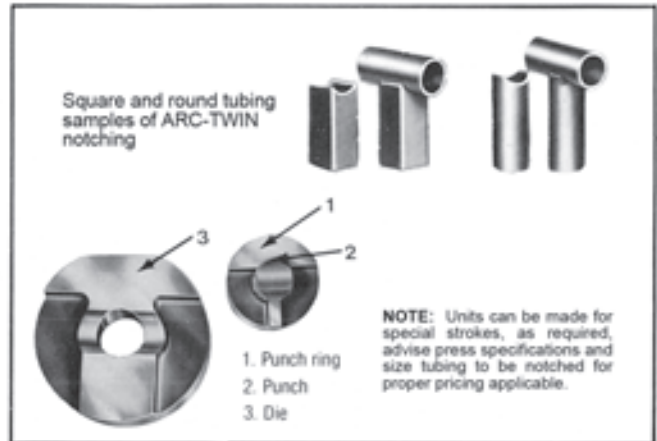

ARC-TWIN STANDARD AND TANDEM UNITS



STANDARD UNIT

Notches both sides of one pipe or tube end in one press stroke

UNIT	MAXIMUM CAPACITY				SIZE		WEIGHT IN LBS.	PRESS REQUIREMENTS		
	PIPE	TUBING	SQ.	WALL	L to R*	F to B		SHUT	STROKE	TONS
101-DS	2"	2 ³ / ₈ "	2"	.154"	20" (27")	8 ¹ / ₂ "	160	7"	3"	30-45
103-DS (Tandem)	2"	2 ³ / ₈ "	2"	.154"	20" (27")	8 ¹ / ₂ "	220	7"	3"	30-45
300-DS	2 ¹ / ₂ "	3"	2 ⁵ / ₈ "	.203"	20" (30")	11 ¹ / ₂ "	350	9 ¹ / ₂ "	6"	45-60
324-DS	2" X 4" RECTANGULAR				20" (30")	11 ¹ / ₂ "	350	9 ¹ / ₂ "	6"	45-60

See Vogel Price Sheet for selection of proper punch and die assemblies.
*Left & Right Dimensions in parenthesis include spring rod.

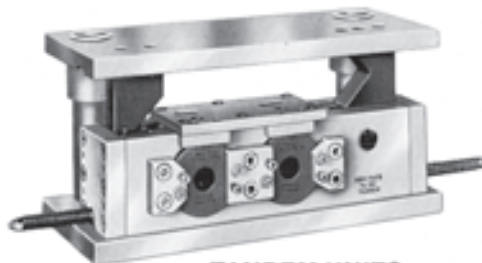

TANDEM UNITS

ARC-TWIN TANDEM UNITS

Notches both sides of two tubes with one press stroke. Consult factory for models and specifications



NO. 110 VOGEL MANUAL OUTBOARD LOCATOR

with one locator post (specify dia.) Additional Locator Posts available. (specify dia. when ordering).

VOGEL SELF CONTAINED HYDRAULIC ARC-TWIN UNITS



UNIT	MAXIMUM CAPACITY				SIZE		WEIGHT IN LBS.	UNIT SPECIFICATIONS
	PIPE	TUBE	SQ.	WALL	L to R	F to B		
101 HPP	2"	2 ³ / ₈ "	2"	.154"	30"	22"	525	5 H.P. Motor 440 V., 3 PH, 60HZ 12 Gal. Optional 220 V. Available
301 HPP	2 ¹ / ₂ "	3"	2 ⁵ / ₈ "	.203"	32"	25"	940	5 H.P. Motor 440 V., 3 PH, 60HZ 12 Gal. Optional 220 V. Available
501 HPP	4 ¹ / ₂ "	5"	4 ¹ / ₂ "	.258"	44 ¹ / ₂ "	21"	1100	10 H.P. Motor 440 V., 3 PH, 60HZ 30 Gal. Optional 220 V. Available

DOUBLE END UNITS ALSO AVAILABLE



VOGEL ARC-FIT® "ANGULAR" UNITS
For making (35° minimum) angular pipe and tubing joints

The Arc-Fit Angular is designed for ONE angle of intersection between the centerline of the notched and mating pipes. 35° as shown in illustration below is standard, but other angles may be ordered. Please specify Pipe Size & Schedule (wall thickness), Mating Pipe Size and Angle of Intersection at time of order. Note that by not fully inserting pipe into first station, a slightly shallower angle can be created. The housing may be re-used with different assemblies to accommodate other pipe sizes, angles, etc.

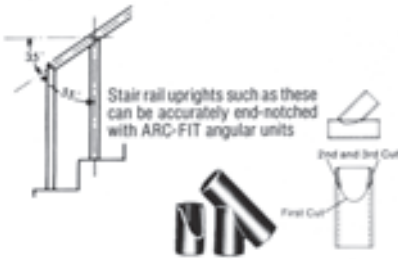
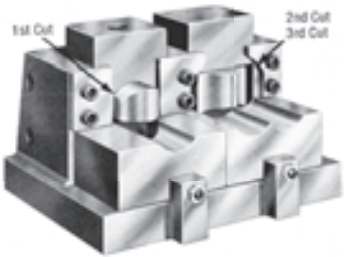

Unit	Max. Capacity			Size		Weight in LBS	Press Requirements		
	Pipe	OD	Wall	L to R	F to B		Shut	Stroke	Tons
75A Housing	1-1/2"	1.90"	.200"	10"	8-1/8"	45	6"	1"	15 - 20
Assembly	Pipe	OD	Wall	Fits Housing		Weight	Angle of Intersection		
9215A	1-1/4"	1.66"	.140"	75A		30	35° as shown in illustration		
9216A	1-1/2"	1.90"	.145"	75A		30	35° as shown in illustration		
14111A	N/A	1-1/2"	1/8"	75A		30	35° as shown in illustration		

Our most popular assemblies are listed above. Optional Spanker Bar available [required for use in Vogel CSP Press] Larger capacity units, other pipe and tube assemblies & other angles available

VOGEL ARC-SNUG® UNITS

The Arc-Snug is designed for ONE angle, 25° to 90°, between the centerline of the notched and mating tubes. Please specify Tube OD, Gauge, Mating OD & Angle of Intersection at time of order The housing may be re-used with different assemblies to accommodate other pipe sizes, angles, etc.



Unit	Max. Capacity		Size		Weight in LBS (incl. Assembly)	Press Requirements		
	OD	Wall	L to R	F to B		Shut	Stroke	Tons
400	1-1/4"	.125"	12"	9"	95	6"	2"	30
450	2"	.187"	12"	9"	147	7-1/2"	3"	35 - 40
455	2-1/2"	.187"	12"	9"	160	7-1/2"	3" - 4"	50 - 60
500	3"	.250"	13"	12"	210	10-1/2"	4"	60 - 80

All Arc-Snug Housings & Assemblies are made to order to suit your application. Arc-Snug & Mitre-Snug tools use the same housings.

VOGEL MITRE-SNUG® UNITS

The Mitre-Snug is designed for ONE angle, between 25° to 89°, as shown in illustration at left. Please specify Tube OD, Gauge & Angle at time of order. The housing may be re-used with different assemblies to accommodate other tube sizes, angles, etc.

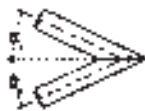

Unit	Max. Capacity		Size		Weight in LBS (incl. Assembly)	Press Requirements		
	OD	Wall	L to R	F to B		Shut	Stroke	Tons
400	1-1/4"	.125"	12"	10"	95	6"	2"	30"
450	2"	.187"	12"	12"	147	7-1/2"	3"	35 - 40
455	2"	.187"	12"	12"	147	7-1/2"	3" - 4"	50 - 60
500	3"	.250"	13"	12"	210	10-1/2"	4"	60 - 80

All Mitre-Snug Housings & Assemblies are made to order to suit your application. Mitre-Snug & Arc-Snug tools use the same housings.



DEMOUNTABLE UNITS D & DD style units designed to be installed, top & bottom, in die set, not included.
DK & DDK units are keyed, top & bottom, for press brake mounting.

Vogel **Perf-Arc** units offer both low cost and versatility for your piercing applications. Units can be used individually, or in multiples, to pierce all holes in a part simultaneously. DD style units pierce a hole top & bottom in unit, and may be ordered to produce one size hole on top and a different size on bottom. Punches are easily sharpenable. Because Perf-Arc units contain the full circumference of the tube, no OD bulging will occur. Units are self-stripping. Each tool is made for a specific size tube and hole, up to maximums shown in charts below. Demountable units may be easily changed to new hole sizes simply by ordering additional perforators.

Dimpled Hole One Side Only

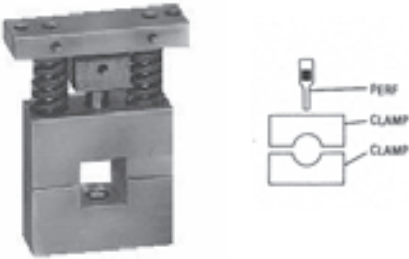

Unit	Capacity			Size		Weight in LBS.	Press Requirements		
	OD	SQ	Hole	Width	F to B		Shut	Stroke	Tons
627-D	1-1/4"	1-1/4"	.500"	1-1/4"	4-7/8"	6	4-7/8"	1-15/16"	10
627-DK	1-1/4"	1-1/4"	.500"	1-1/4"	4-7/8"	7	4-7/8"	1-15/16"	10
637-D	2"	2"	.750"	2"	5-3/4"	16	6-1/2"	2-13/16"	15
637-DK	2"	2"	.750"	2"	5-3/4"	18	6-1/2"	2-13/16"	15
647-D	3"	3"	1.000"	2-1/4"	8"	34	9-3/8"	4-1/16"	20
647-DK	3"	3"	1.000"	2-1/4"	8"	37	9-3/8"	4-1/16"	20

Dimpled Hole Both Sides

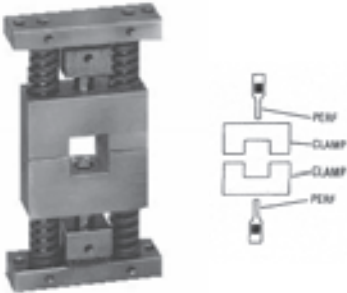

Unit	Capacity			Size		Weight in LBS.	Press Requirements		
	OD	SQ	Hole	Width	F to B		Shut	Stroke	Tons
627-DD	1-1/4"	1-1/4"	.500"	1-1/4"	4-7/8"	7	6-3/4"	2-9/16"	15
627-DDK	1-1/4"	1-1/4"	.500"	1-1/4"	4-7/8"	8	6-3/4"	2-9/16"	15
637-DD	2"	2"	.750"	2"	5-3/4"	18	8-1/2"	3-9/16"	25
637-DDK	2"	2"	.750"	2"	5-3/4"	20	8-1/2"	3-9/16"	25
647-DD	3"	3"	1.000"	2-1/4"	8"	37	11-3/4"	5-1/16"	30
647-DDK	3"	3"	1.000"	2-1/4"	8"	41	11-3/4"	5-1/16"	30

SELF CONTAINED UNITS These units require mounting of the unit's base only.

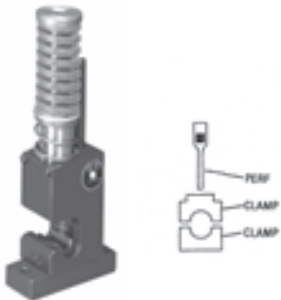

DIMPLED HOLE TOP WALL, CLEAN HOLE BOTTOM WALL

Unit	Capacity			Size		Weight in LBS.	Press Requirements		
	OD	SQ	Hole	Width	F to B		Shut	Stroke	Tons
629	1"	1"	.500"	2"	4-3/4"	12	9-13/16"	2-1/4"	10
639	1-1/2"	1-1/2"	.750"	2-1/2"	5-1/4"	20	11-1/8"	3-1/4"	15
649	2"	2"	1.000"	3"	6-1/2"	42	15-1/4"	4-3/8"	20

Note: Exit hole (bottom wall) will be larger, due to slug clearance. Typically the increase is up to 25% of the tube's wall thickness. [Example: for a 16 gauge tube, this means an exit hole up to .0163" larger]

Dimple Piercing

"How much dimple can I expect?" This is the question we get asked most. The amount of dimple these tools produce is based on many factors, including, hole size in relation to tube ID, weld seam location, tube material and gauge, tooling sharpness, press speed, amount & type of lubrication used. For this reason, we cannot estimate the dimple you can expect. These tools are perfect when the exact amount of dimple is not critical, and variation in dimple (i.e. as tooling dulls); will not impact part function, such as clearance holes, bolt holes, etc.

Clean Hole Piercing

Clean hole piercing requires an ID support to the tube. Our Perf-Arc tools are NOT appropriate when clean hole piercing is required. Tools of this type are normally built in a die set to help guide the tooling. The tooling is designed, built and priced based on the application. If your project requires clean hole piercing, please send us a drawing of your part.

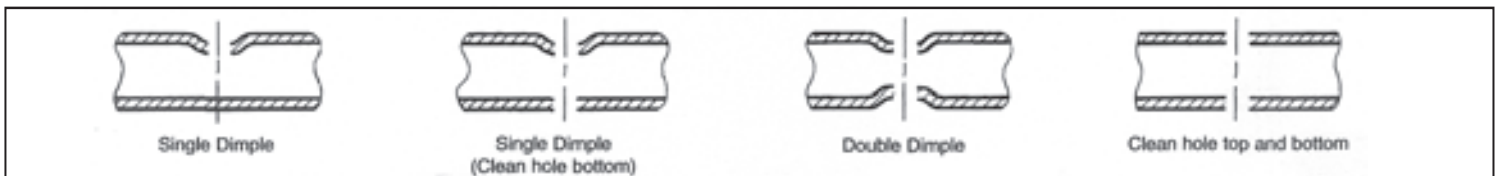

VOGEL "V" NOTCHING AND SIDE NOTCHING OF TUBING AND PIPE



V NOTCH, REAR WALL INTACT. FOR NOTCHING SQUARE OR RECTANGULAR TUBING



Rear wall intact for 90° corners
(Slight Dimpling Occurs on Entrance Side)

"V" Notch Units can notch square or Rectangular Tubing within their square capacity. The tubing is automatically clamped and unclamped for easy insertion and removal of the workpiece. The Units come complete with one set of tooling for one size and wall (advise when ordering) Front Spacers are changed with different sizes (shimmed for different wall thicknesses). The Rear Cams are changed for different wall thicknesses.

UNIT	CAPACITY (MAX)		SIZE		WEIGHT IN LBS.	PRESS REQUIREMENTS		
	SQ.	WALL	L TO R	F TO B		SHUT	STROKE	TONS
206AA	1½"	.125"	12¼"	11¼"	167	7"	4"	30
207	2" x 3"	.125"	12"	12"	175	8"	5½"	40

*NOTE: Stroke shown is the minimum stroke required to side load the tool. To front load add 1" for the 206AA and 3" for the 207
**3" Standing up.

SPECIAL SIDE NOTCH DIE For flow through joints where the size of the mating tube makes the hole in the Header too large to be pierced in an Arbor Piercing Die or where large windows must be pierced in tubing Special Side Notch Dies are used.



SPECIAL SIDE NOTCHING DIE
Notches a circular side notch in 4" pipe. Includes clamp-up action and air shudder for easy removal of part.

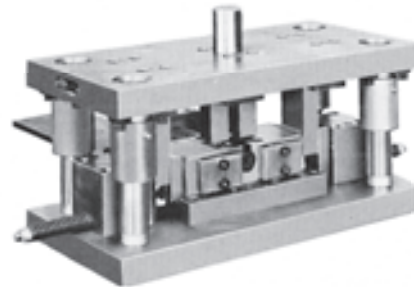

SPECIAL DOUBLE SIDE NOTCH DIE
With double clamp-up action to notch two 1" long by ¼" wide windows in 1" O.D. x 20 Ga. tubing.



LINDERS ABC-ABRASIVE BELT COPER

The ABC Coper can be used on Tube, Pipe, Channel, Angle or Bar to make a precise joint with a round surface in just a few minutes. Just clamp the work piece into the quick clamp on the Coper and adjust for the proper angle. The finished joint can be welded, brazed or silver soldered. The Unit comes complete with one size spindle (advise the diameter desired) and one abrasive belt.

Unit	Capacity			Length	Width	Height	Weight	Belt	Motor	Power
	Vise	Spindle Dia.	Miter Angle							
ABC Coper	3-1/2" OD or Sq.	5" OD	45° - 90°	78"	24"	16"	350 Lbs	5" x 132"	5HP	230 / 460V 3Phase



Clean, Close Fitting Joints

ABC Coper is a product of Linders Mfg. Co.

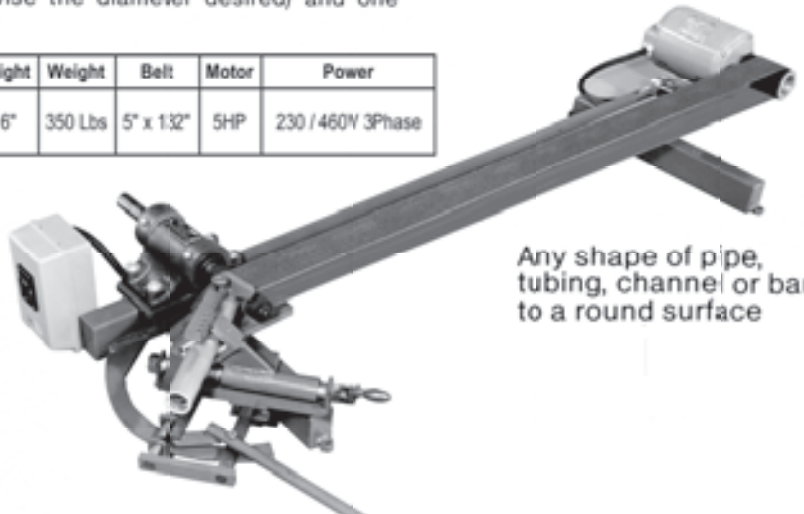

Any shape of pipe, tubing, channel or bar to a round surface

VOGEL CUSTOM DIES

SPECIAL VOGEL SINGLE & MULTI OPERATION DIES

(Typical Examples)

For over half a century, Vogel has specialized in custom dies tailored to your unique tube fabricating requirements. Dies shown on this page are just a few of the many types of custom dies Vogel offers. Because these dies are custom built, costs will vary with the application. Please fax us a complete part print showing all part details, tolerances, etc. Please include an estimate of your annual production needs.

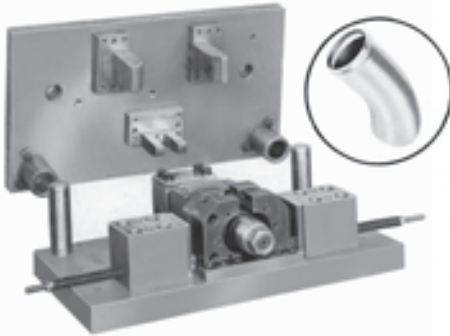

SPECIAL URETHANE BEADING DIE

For beading 2 1/2" x 16 ga. tubing. Since clamp up action is required in the bead area only, the part can be bent prior to beading.



SPECIAL TWO STATION FLATTEN RADIUS FORM AND PIERCE DIE

To form 1" schedule 40 pipe 5 1/2" back. Second station to pierce a .406" dia. hole 2 1/2" from end.



SPECIAL CENTERLINE FLATTEN AND PIERCE DIE

For 1" O.D. x 16 ga. stainless steel tubing.

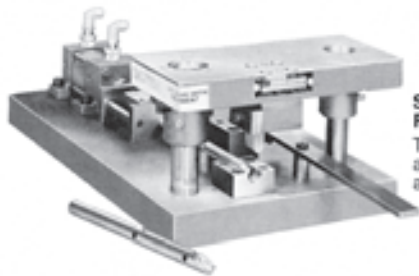

SPECIAL END FORMING DIE

To form and seal one end of a 1/2" O.D. tube with gauging and air ejection.

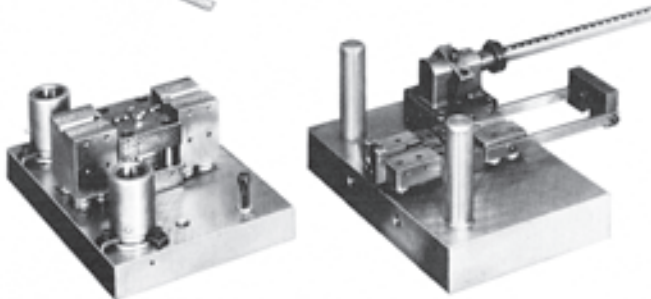

SPECIAL CENTERLINE FLATTEN, FORM, PIERCE, COIN AND CUTOFF DIE

For 1/2" O.D. x 18 ga. tubing with automatic gauging and stop. Makes one complete part per press stroke.



SPECIAL FEED THRU DOUBLE FLATTEN, RADIUS TRIM AND PIERCE DIE

Performs all three operations in one press stroke.

SPECIAL THROATLESS SLOTTING DIE

For slotting round, square or rectangular tubing to unlimited depths.

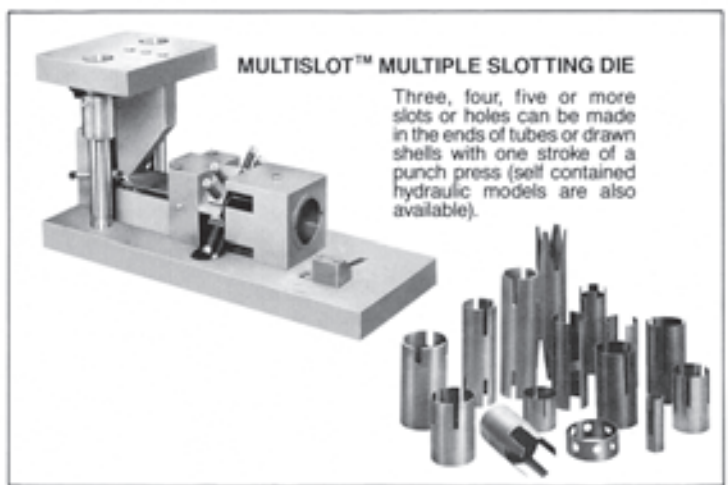

MULTISLOT™ MULTIPLE SLOTTING DIE

Three, four, five or more slots or holes can be made in the ends of tubes or drawn shells with one stroke of a punch press (self contained hydraulic models are also available).

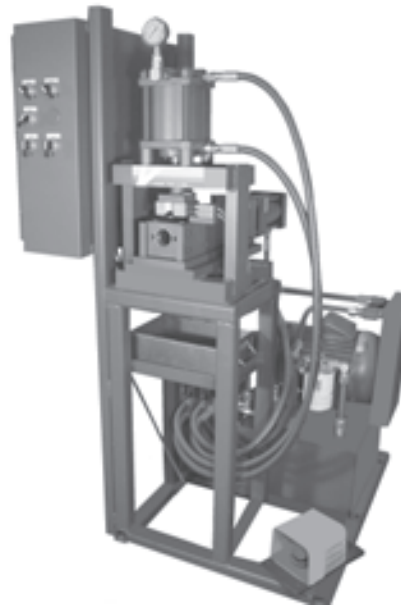

TUBE END FORMING MACHINE

This versatile, self contained, foot pedal actuated machine hydraulically clamps and reduces the tube end automatically. Quick change, interchangeable tooling. Model EM 1.25 for use with mild steel tubing up to 1 1/4" dia. x 14 ga. Consult factory for larger requirements.

VOGEL PICKET FENCE TOOLS, STRUCTURAL SHAPE TOOLS, CORNER NOTCHING TOOLS

PICKET FENCE TOOLS, STRUCTURAL SHAPE TOOLS, CORNER NOTCHING TOOLS

Depend on Vogel to provide you with the equipment to make your own picket fence panels right in your own shop. Our Picket Fence Pointer turns square tubing into a spear-point picket. Companion tools allow you to pierce square tubing or channel to form the horizontal rails. Add our compact power units (see pg. 10) and you have everything you need to produce these fence components.

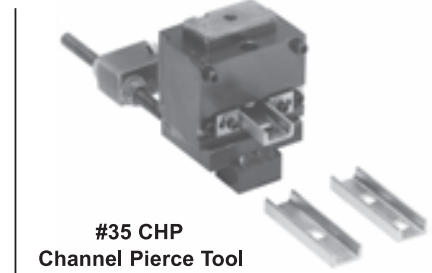
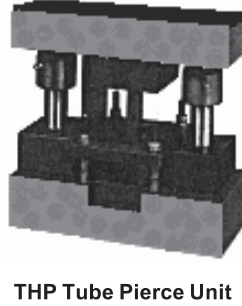
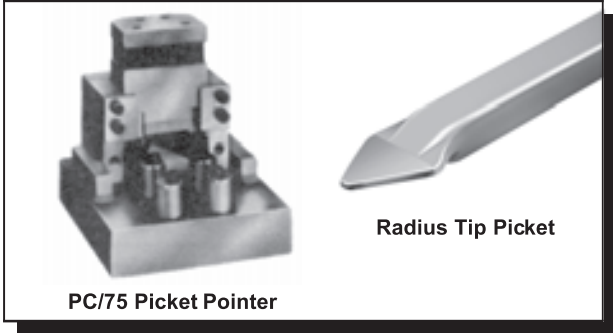
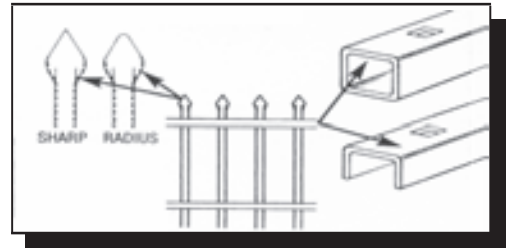

Unit	Max. Capacity			Max. Hole Size	Size		Weight in LBS	Press Requirements		
	Material	Size	Wall		L to R	F to B		Shut	Stroke	Tons
PC/75	Tubing	1" sq	16 ga.	N/A	8"	8-1/2"	65	7-3/4"	1-1/4"	15
PC/75R	Tubing	1" sq	16 ga.	N/A	8"	8-1/2"	65	7-3/4"	1-1/4"	15
#35CHP	Channel	1/2" x 1-1/4" x 1/2"	1/8"	17/32" square	4-1/2"	3-5/8"	15	5"	7/16"	7
#75CHP	Channel	1" x 2" x 1"	3/16"	1-1/4" square	8"	6"	50	6"	1"	30
THP	Tubing / Channel	1-1/2"	1/8"	1-1/4" square	9-1/2"	4-3/4"	50	6-15/16"	2-1/16"	15

SHEARS FOR HEAVY DUTY APPLICATIONS

HOUSING	ROD	ANGLE	FLAT	CHANNEL*	HOUSING WITH ASSEMBLY SPECIFICATIONS					
PART NO.	PART NO./CAPACITY	PART NO./CAPACITY	PART NO./CAPACITY	PART NO./CAPACITY	SIZE		UNIT WEIGHT (LBS.)	PRESS REQUIREMENTS		
					L to R	F to B		SHUT	STROKE	TONS
221 HSG For use with all 221 assemblies	221RS 1/8", 1/4", 3/8", 1/2", 5/8", 3/4"	221AS 1-1/4" x 1-1/4" x 1/4"	221FS 3/8" x 1-1/2"	221CS 2" L to R 2-1/4" T to B	8"	3-1/2"	35	5"	5/8"	15
222 HSG For use with all 222 assemblies	222RS 1/4", 3/8", 1/2", 5/8", 3/4", 7/8", 1", 1-1/8", 1-1/4", 7/8", 1", 1-1/8", 1-1/4"	222AS 3 x 3 x 1/4" 2-1/2" x 2-1/2" 2" x 2" x 1/2"	222FS 3/8" x 4"	222CS 4-1/2" L to R 3" T to B	11-1/2"	4-5/8"	75	7"	1"	40
223 HSG For use with all 223 assemblies	223RS 1", 1-3/8", 1-1/4", 1-3/8", 1/2"	223AS 4 x 4 x 1/4" 3" x 3" x 1/2"	223FS 1/2" x 6"	223CS 6-1/2" L to R 5" T to B	14"	5-1/2"	125	9-1/4"	1-1/8"	75

These scrapless shears may be used to cut rod, angle iron, flat stock, channel and other structural shapes. Three capacity ranges are currently available, each with a standard housing in which the various assemblies easily interchange. All units are designed for stationary recutting applications but may be modified for cutting on the fly.

NOTE: Assemblies for channel and other shapes may be custom made to fit individual requirements.

* Capacities shown for channel and other shapes represent maximum workpiece dimensions. Consult factory.

ANGLE IRON "V" NOTCH AND FLAT STOCK CORNER NOTCH UNITS

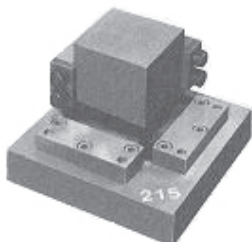

Angle Iron "V" Notch Units are Heavy Duty Self Contained Units with resharpenable inserts for making 90° Corners in Angle Iron and Flat Stock Special Angles and larger sizes can be quoted, consult factory.

"Before and After" views showing how "V" notched angle iron is bent into a right angle corner.



UNIT	CAPACITY (MAX.)			SIZE		WEIGHT IN LBS.	PRESS REQUIREMENTS		
	ANGLE	CORNER	WALL	L to R	F to B		SHUT	STROKE	TONS
213	1-1/4" x 1-1/4"	1-1/4"x1-1/4'	.125	4-1/2"	4-1/2"	10	3-1/4"	1/4"	10
215	3" x 3"	3" x 3"	.375	10"	10"	95	6-1/8"	1"	80
216	4" x 4"	4" x 4"	.500	12"	12"	170	8"	1-1/4"	110

VOGEL HYDRAULIC POWER UNITS

HYDRAULIC CAGE STYLE POWER UNITS

Vogel Cage Style Power Units are the perfect way to provide power to your Vogel Arc-Fit notching tooling and many other types of Vogel tooling. Self-contained, foot-pedal actuated, these units increase efficiency and reduce manual effort. Most units are 110V and simply plug into a standard outlet (20 amp dedicated circuit recommended). If you don't see the right unit for your tooling, please contact the factory to find out if we can custom build a power unit to suit your equipment and application.

Model	Description Accepts the following Vogel Tooling	Weight (in lbs.)	Power Specifications			
			Power Source	Reservoir	Horsepower	Tonnage
CSP-15-SA	#35 Housing	250	110V , 20 amp	1-1/2 Gallons	1.5	15
CSP-25-SA	#35 Arc-Fit Housing #75 Arc-Fit Housing #75 Arc-Fit Angular Housing (Pg. 5) #400 Arc-Snug Housing (Pg. 5) #PC-75 Picket Fence Tool (Pg. 9) THP / CHP Tube / Channel Pierce Tool (Pg. 9)	275	110V , 20 amp	1-1/2 Gallons	1.5	25
CSP-25-DA	Various - Press can be customized to suit tooling requirements	TBD	440V, 3phase	5	3	25
CSP-25-HD/DA	Various - Larger tank & motor for heavy duty use	TBD	440V, 3phase	12	5	25
CSP-HT Hand Truck	CSP-15-SA Hydraulic Cage-Style Power Unit CSP-25-SA Hydraulic Cage-Style Power Unit CSP-25-DA Hydraulic Cage-Style Power Unit	75	N/A	N/A	N/A	N/A

All tooling pictured is sold separately

Still using a #1400 Hand Press to notch tubes & pipes?

Upgrade now to a Vogel CSP Power Unit.

- Increase Production
- Reduce Effort
- Notch up to schedule 80 pipe with ease!*

*Proper assembly req'd



CSP-15-SA with Arc-Fit #35 Housing & Assembly



CSP-HT Hand Truck with CSP-15-SA Power Unit and tooling

Add our **CSP-HT Hand Truck** to any Vogel CSP Power Unit to increase it's versatility. Large-wheels make it easy to move your equipment to where you need it. Don't relocate your work, simply relocate your press. Hand Truck pictured with CSP-15-SA Power Unit, Housing & Assembly sold separately.



CSP-25-SA



CSP-25-SA with Arc-Fit #35 Housing, #201A Punch Press Adaptor & Assembly



CSP-25-SA with Arc-Fit Angular #75 Housing & Assembly

VOGEL CUT OFF DIES & MACHINES

TUBE CUT OFF - Dimple-Free, Minimal Burr

Depend on Vogel for cut off equipment that will help you increase efficiency, while reduce part handling and cost! Our two-blade cutoff technique, originally patented in 1941, cuts tubes, up to 6" OD, with no OD deformation and minimal burr (10% or less of tube's wall thickness). We offer dies for use in your press, self-contained machines and fully automated systems. Virtually all our equipment can be upgraded, to increase the level of automation to best suit your production needs.

<ul style="list-style-type: none"> • No OD Deformation • Minimal Burr • Up to 6" OD capacity 	<ul style="list-style-type: none"> • No chips to remove from part • Minimal scrap loss per cut • Fast production rates 	<ul style="list-style-type: none"> • Low maintenance costs • Low perishable costs • Quick change over
---	---	--

CUT OFF DIES

Each cut off die will handle a wide range of tube sizes, up to the maximum capacity shown. To change the size of tube to be cut, simply change the die inserts that clamp the tube. The insert changeover may be performed with the cut off die in the press, to reduce down time. Inserts are sharpenable, and typically can perform in excess of 20,000 - 40,000 cuts between sharpenings, depending on tube material and wall thickness. Blades are low-cost, easily sharpenable and replaceable. Our horizontal blade design is reversible for a fresh edge without resharping.

Cut Off Dies, 2-Blade for Dimple-Free Cuts on Rounds, Squares & Rectangles										
Unit	Max. Capacity			Size		Weight in LBS	Insert Length	Press Requirements		
	OD	Sq.	Wall	L to R	F to B			Shut	Stroke	Tons
1P	1"	3/4"	.125"	18"	9"	250	1-1/2"	7-1/8"	3"	20
2P	2"	1-1/2"	.145"	19"	11"	335	2-1/2"	8-1/2"	5" to 6"	40
3P	3"	2-1/8"	.187"	24"	12-1/2"	435	3"	11-1/8"	6"	70
4P	4"	2-13/16"	.250"	28"	17"	520	4"	14-9/16"	7"	120
6P	6"	3-7/16"	.250"	36"	18"	950	4"	14-1/2"	10"	160

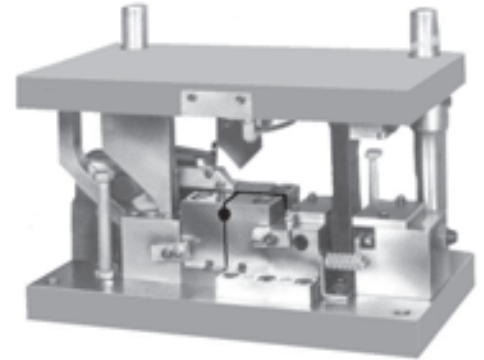

2P Cut Off Die

Cut Off Dies, Single-Blade for Dimple-Free Cuts on Squares & Rectangles										
Unit	Max. Capacity			Size		Weight in LBS	Insert Length	Press Requirements		
	OD**	Sq.	Wall	L to R	F to B			Shut	Stroke	Tons
5827	1-1/8"	1-1/8"	.125"	16"	5"	90	2-1/4"	7"	3"	20
2LHP	2"	1-1/2"	.145"	19"	11"	335	2-1/2"	8-1/2"	5" to 6"	40
3LHP	3"	2-1/8"	.187"	24"	12-1/2"	435	3"	11-1/8"	6"	70
4LHP	4"	2-13/16"	.250"	28"	17"	520	4"	14-9/16"	7"	120
6LHP	6"	3-7/16"	.250"	36"	18"	950	4"	14-1/2"	10"	160

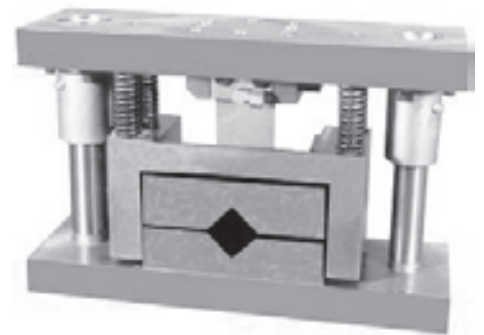

5827 Cut Off Die

5827 Cut Off Die has one blade for dimple-free cuts on squares. It will **dimple cut round tubing and is not upgradable to two-blade design. LHP Cut Off Dies have one blade for dimple-free cuts on squares, **dimples on rounds, it CAN be upgraded to a two-blade design for dimple free cuts on round tubing. Insert length indicates minimum part length. For all cut off dies except 5827, die inserts may be incut, at an additional charge, for shorter part lengths.

CUT OFF MACHINES

Vogel cut off machines incorporate the same cut off technology described above, but in a self-contained compact footprint. If press availability is an issue, our complete machines are the perfect choice. Manual feed machines include a micro-switch stop assembly to signal the machine to cycle. Many levels of automation are available, including auto-feeding, automatic sorting of scrap and finished parts, bundle unscramblers and more. Vogel can customize a machine or system to meet your cut off requirements, space and budget.

Unit	Max. Capacity			Strokes per Minute	Standard Hydraulics			Weight in LBS
	OD	Sq.	Wall		HP	GPM	Tank	
2040-H-50	2"	1-1/2"	.125"	55 - 60	30	47	100	3500
3050-H-60	3"	2-1/8"	.187"	45 - 50	50	90	100	4500
4060-H-75	4"	2-13/16"	.187"	30 - 50	50	90	150	6000

Strokes per minute do not include material feed time.

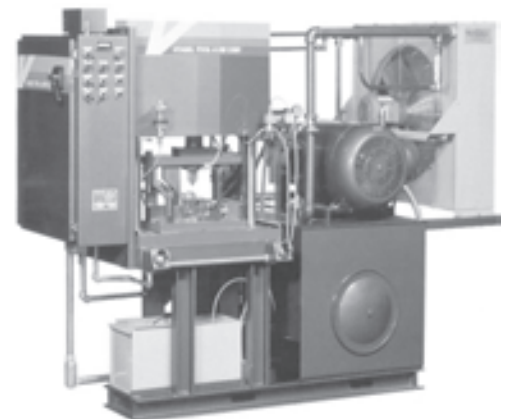

2040-H-50 Cut Off Machine
Manual Feed

Fully Automated Cut Off Systems Available - Contact Factory

VOGEL TOOL & DIE

A Division of T-E-S Tube Equipment, Inc.

Tube & Pipe Fabricating Tools, Dies & Equipment

PIPE AND TUBING SCHEDULES

ANSI PIPE SCHEDULES figures indicate wall thickness in inches

PIPE SIZE	O.D. in inches	5	10	20	30	40 STD	60	80 XH	100	120	140	160	XXH
1/8	.405	.035	.049			.068		.095					
1/4	.540	.049	.065			.088		.119					
3/8	.675	.049	.065			.091		.126					
1/2	.840	.065	.083			.109		.147				.187	.294
3/4	1.050	.065	.083			.113		.154				.218	.308
1	1.315	.065	.109			.133		.179				.250	.358
1 1/4	1.660	.065	.109			.140		.191				.250	.382
1 1/2	1.900	.065	.109			.145		.200				.281	.400
2	2.375	.065	.109			.154		.218				.343	.436
2 1/2	2.875	.083	.120			.203		.276				.375	.552
3	3.500	.083	.120			.216		.300				.437	.600
3 1/2	4.0	.083	.120			.226		.318					.636
4	4.50	.083	.120			.237	.281	.337		.437		.531	.674
4 1/2	5.0					.247		.355					.710
5	5.563	.109	.134			.258		.375		.500		.625	.750
6	6.625	.109	.134			.280		.432		.562		.718	.864
7	7.625					.301		.500					.875
8	8.625	.109	.148	.250	.277	.322	.406	.500	.593	.718	.812	.906	.875
9	9.625					.342		.500					

MECHANICAL TUBING WALL GAUGES Birmingham Wire Gauge (BWG) Equivalent

GAUGE	DEC. IN INCHES	GAUGE	DEC. IN INCHES	GAUGE	DEC. IN INCHES	GAUGE	DEC. IN INCHES
28	.014	20	.035	12	.109	4	.238
27	.016	19	.042	11	.120	3	.259
26	.018	18	.049	10	.134	2	.284
25	.020	17	.058	9	.148	1	.300
24	.022	16	.065	8	.165	0	.340
23	.025	15	.072	7	.180	00	.380
22	.028	14	.083	6	.203	000	.425
21	.032	13	.095	5	.220	0000	.454

ELECTRICAL CONDUIT DIMENSIONS

EMT			IMC			RIGID		
NOMINAL TRADE SIZE	OUTSIDE DIAMETER	WALL THICKNESS	NOMINAL TRADE SIZE	OUTSIDE DIAMETER	WALL THICKNESS	NOMINAL TRADE SIZE	OUTSIDE DIAMETER	WALL THICKNESS
1/2	0.706	0.042	1/2	0.815	0.070	1/2	0.840	0.104
3/4	0.922	0.049	3/4	1.029	0.075	3/4	1.050	0.107
1	1.163	0.057	1	1.029	0.085	1	1.315	0.126
1 1/4	1.510	0.065	1 1/4	1.638	0.085	1 1/4	1.660	0.133
1 1/2	1.740	0.065	1 1/2	1.883	0.090	1 1/2	1.900	0.138
2	2.197	0.065	2	2.360	0.095	2	2.375	0.146
2 1/2	2.875	0.072	2 1/2	2.857	0.130	2 1/2	2.875	0.193
3	3.500	0.072	3	3.476	0.130	3	3.500	0.250
3 1/2	4.000	0.083	3 1/2	3.971	0.130	3 1/2	4.000	0.215
4	4.500	0.083	4	.466	0.130	4	4.500	0.225
5						5	5.563	0.245
6						6	6.625	0.266

All dimensions in inches.