

UNITTOOL

HEAVY-DUTY PUNCHING UNITS

**Model H • Model HP
Model HA • Model HH
Model HFT**

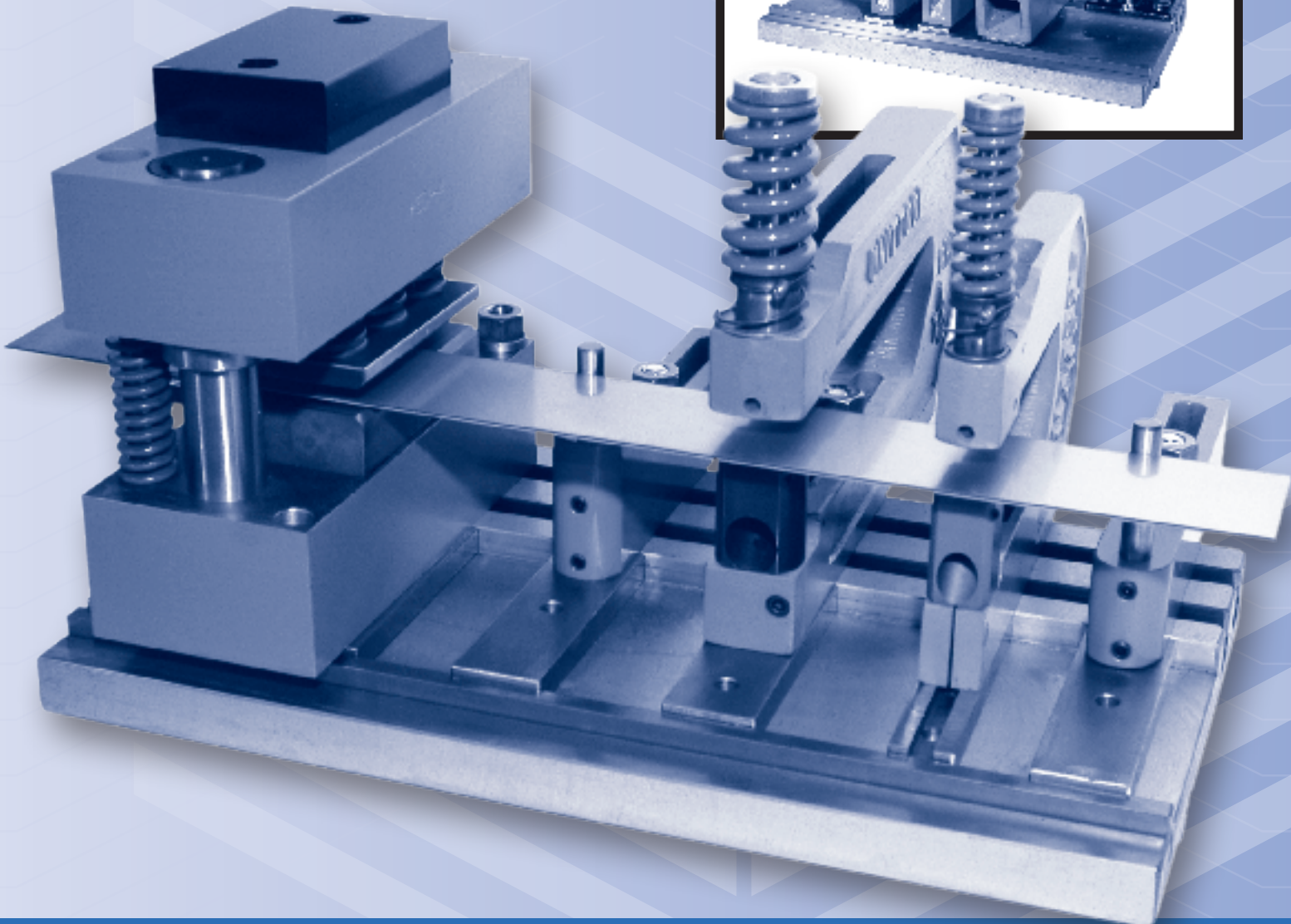

UNITTOOL PUNCH & DIE COMPANY INC.

20 Norris St. Buffalo, New York 14207 | Phone: 1-716-873-8453 | Fax: (USA Only) 1-800-25Punch (257-8624)
Email: Info@Unittool.com

UNITTOOL "H" SERIES PUNCHING UNITS

8³/₈" SHUT HEIGHT

Punch size range — .093 to 5.00 dia.

3¹/₂" DIE HEIGHT

Capacity up to ³/₄" thick mild steel

UNITTOOL'S HEAVY-DUTY SERIES PUNCHING UNITS are designed for rugged punching operations. Many new outstanding features are prominent in this equipment, such as, 80,000 pound tensile strength holders, 4140 alloy steel guides, oil hardening tool steel punches and dies. The units can be furnished for either round or shaped hole punching. The "C" frame holders are keyed for shaped hole punching at no extra cost. The base of the holders are provided with a pilot pin hole machined on the center line of the punch and die bore for quick and accurate template location. A second pilot pin location is machined 1¹/₂" behind the front pilot hole. The purpose of the second pilot pin location is to prevent the holders from pivoting when shaped punches and dies are used in the units.

index

MODEL H

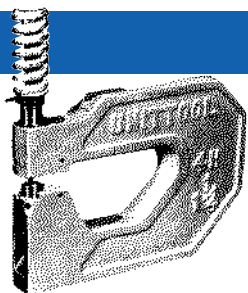

PAGES 3-11

MODEL H

This popular unit will serve most applications. Low in cost with inexpensive die buttons.

MODEL HH

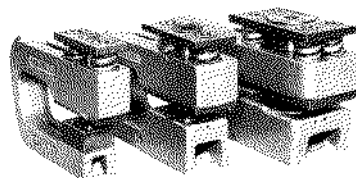

PAGES 18-22

MODEL HH

The HH series of holders are extra heavy-duty in design to handle mild steel up to ¹/₂" thick.

MODEL HP

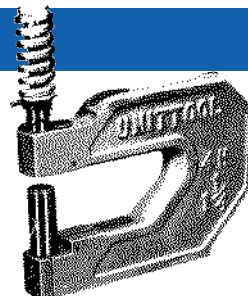

PAGES 12-16

MODEL HP

Designed with a pedestal die section to allow die to be "ground away" in order to punch close to an inside leg of an angle or other obstructions. The pedestal die can be revolved 360 degrees in order to direct slug ejection chute in any desired direction. (Round hole only).

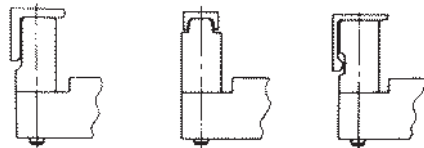

MODEL HH-3

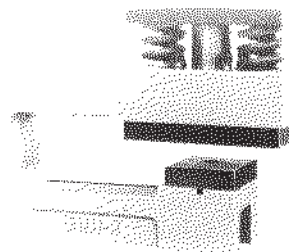

PAGES 19

MODEL HH-3

This unit has the capacity of punching holes in material up to ³/₄" thick.

MODEL HFT

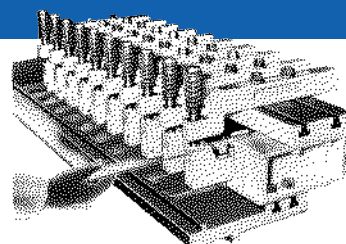

PAGES 22-24

MODEL HFT

Heavy-Duty Feed Thru Punching Units are designed to feed the material through from the front or back of press.

MODEL HA

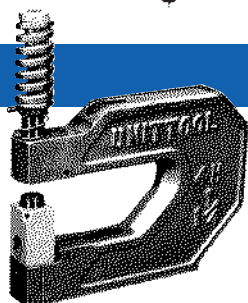

PAGES 12-15

MODEL HA

The "C" frame holder in this model is the same holder used in the Model HP unit. The use of a die button adapter permits the use of inexpensive die button replacements. The adapter can be revolved 360 degrees in order to direct slug ejection chute in any desired direction. (Round hole only).

SHAPED HOLE PUNCHING DATA

PAGE 25

COMPENSATOR CAPS AND PUNCH ADAPTER GUIDES

PAGE 26

MODEL H-1"

	CAT. NO.	THROAT DEPTH	HOLDER WIDTH	LENGTH A	LENGTH B	LENGTH C
8 3/8" SHUT HEIGHT	4H-1	4 5/8	1"	7 7/8	1 7/8	—
	8H-1	8 5/8	1"	11 7/8	5 3/8	—
3 1/2" DIE HEIGHT	12H-1	12 5/8	1"	15 7/8	5 7/8	—

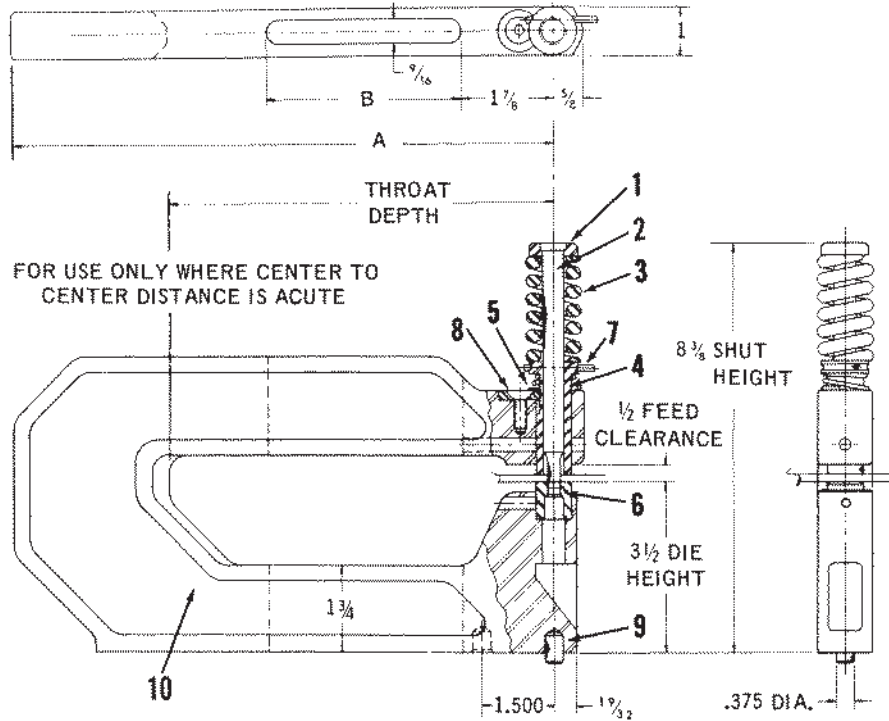
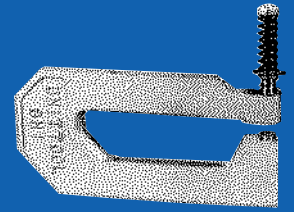

5/16" MAX. PUNCH SIZE FOR 1/4" THICK MATERIAL • 7/16" MAX. PUNCH SIZE FOR 1/8" MATERIAL

ITEM NO.	DESCRIPTION	CATALOG NO.	ITEM NO.	DESCRIPTION	CATALOG NO.
1	Punch Head	HPH-107	10	(1) Holder 4" Throat	4H 1C
2	Punch (Without Head)	HP-122		(1) Holder 8" Throat	8H 1C
—	Shaped Punch & Head Ass'y.	HPA-102K		(1) Holder 12" Throat	12H 1C
—	Punch & Head Ass'y.	HPA-102A	11	Conversion Kit	HCK-100
3	Stripper Spring	HSS-105		(1) Includes Pilot Pin & Guide Retainer	
4	Guide (Not Keyed)	HG-104			
—	Keyed Guide	HG-104K			
5	Lifter Spring	HLS-106			
6	Die Button	HD-123			
—	Shaped Die	HD-123K			
7	Punch Retainer	PR-100			
8	Guide Retainer	GR-300			
9	Pilot Pin	PP-1000			
—	Pilot Pin (Diamond)	PP-1000K			

MINIMUM RECOMENDED
DIE CLEARANCE .006

MODEL H-1 1/4"

	CAT. NO.	THROAT DEPTH	HOLDER WIDTH	LENGTH A	LENGTH B	LENGTH C
8 3/8" SHUT HEIGHT	4H-1 1/4	4 5/8	1 1/4	7 7/8	1 7/8	—
	8H-1 1/4	8 5/8	1 1/4	11 7/8	5 3/8	—
3 1/2" DIE HEIGHT	12H-1 1/4	12 5/8	1 1/4	15 7/8	5 7/8	3

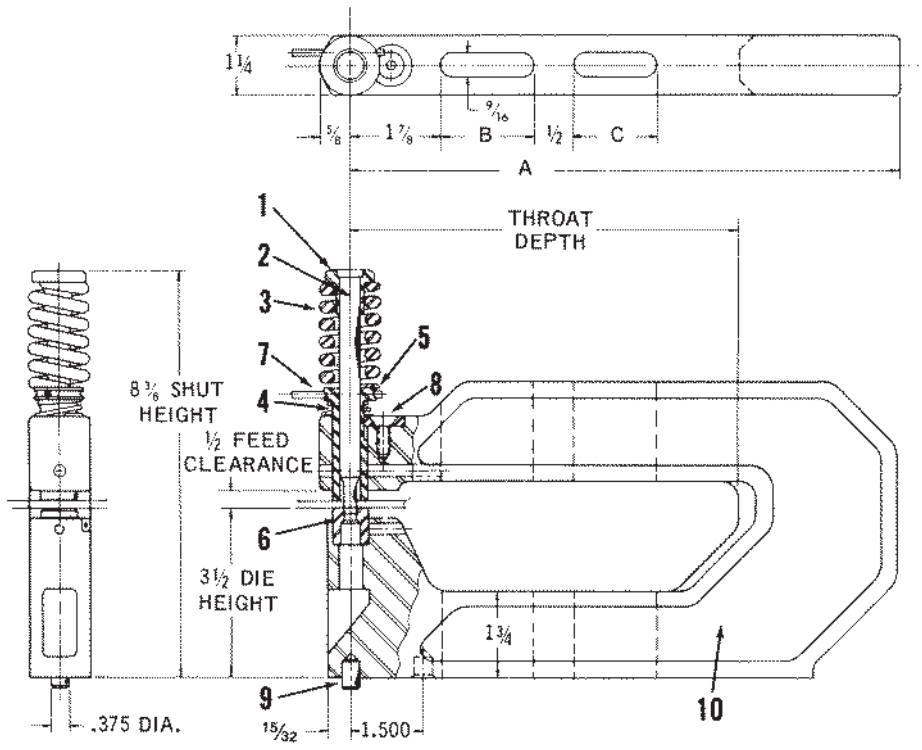
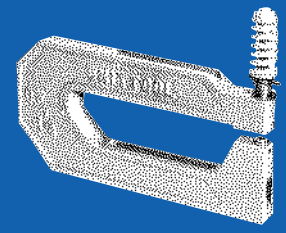

MIN. PUNCH SIZE .093

MAX. PUNCH SIZE .437

MAX. MATERIAL THICKNESS 1/4"

ITEM NO.	DESCRIPTION	CATALOG NO.	ITEM NO.	DESCRIPTION	CATALOG NO.
1	Punch Head	HPH-127	10	(1) Holder 4" Throat	4H 1 1/4C
2	Punch (Without Head)	HP-122		(1) Holder 8" Throat	8H 1 1/4C
—	Shaped Punch & Head Ass'y.	HPA-122K		(1) Holder 12" Throat	12H 1 1/4C
—	Punch & Head Ass'y.	HPA-122A	11	Conversion Kit	HCK-125
3	Stripper Spring	HSS-125		(1) Includes Pilot Pin & Guide Retainer	
4	Guide (Not Keyed)	HG-124			
—	Keyed Guide	HG-124K			
5	Lifter Spring	HLS-126			
6	Die Button	HD-123			
—	Shaped Die	HD-123K			
7	Punch Retainer	PR-100			
8	Guide Retainer	GR-300			
9	Pilot Pin	PP-1000			
—	Pilot Pin (Diamond)	PP-1000K			

**MINIMUM RECOMENDED
DIE CLEARANCE .006**

MODEL H-1 1/2"

	CAT. NO.	THROAT DEPTH	HOLDER WIDTH	LENGTH A	LENGTH B	LENGTH C
8 3/8" SHUT HEIGHT	4H-1 1/2	4 5/8	1 1/2	7 7/8	1 3/8	—
	8H-1 1/2	8 5/8	1 1/2	11 7/8	5 3/8	—
	12H-1 1/2	12 5/8	1 1/2	15 7/8	5 7/8	3
3 1/2" DIE HEIGHT	18H-1 1/2	18 5/8	1 1/2	21 7/8	5 7/8	5 3/8
	24H-1 1/2	24 5/8	1 1/2	27 7/8	5 7/8	5 3/8

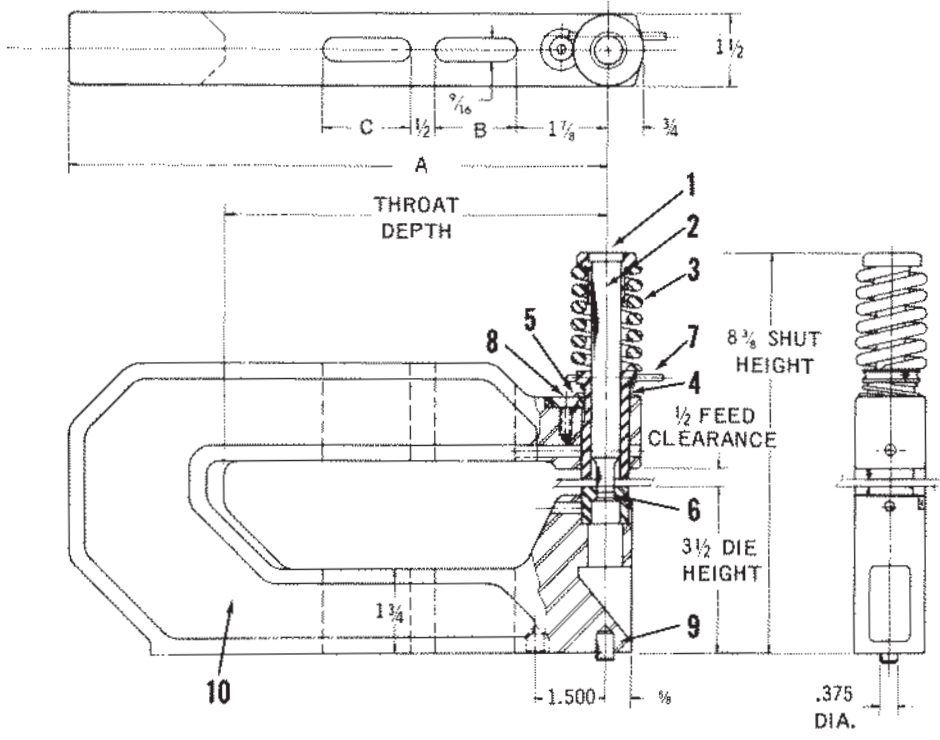
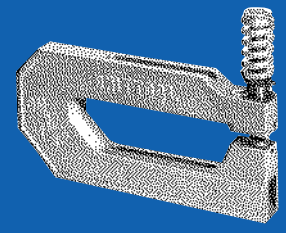

MIN. PUNCH SIZE .1875

MAX. PUNCH SIZE .625

MAX. MATERIAL THICKNESS 1/4"

ITEM NO.	DESCRIPTION	CATALOG NO.	ITEM NO.	DESCRIPTION	CATALOG NO.
1	Punch Head	HPH-157	10	(1) Holder 4" Throat	4H 1 1/2C
2	Punch (Without Head)	HP-152		(1) Holder 8" Throat	8H 1 1/2C
—	Shaped Punch & Head Ass'y.	HPA-152K		(1) Holder 12" Throat	12H 1 1/2C
—	Punch & Head Ass'y.	HPA-152A		(1) Holder 18" Throat	18H 1 1/2C
3	Stripper Spring	HSS-155	11	Conversion Kit	HCK-150
4	Guide (Not Keyed)	HG-154	(1) Includes Pilot Pin & Guide Retainer		
—	Keyed Guide	HG-154K			
5	Lifter Spring	HLS-156			
6	Die Button	HD-153			
—	Shaped Die	HD-153K			
7	Punch Retainer	PR-100			
8	Guide Retainer	GR-300			
9	Pilot Pin	PP-1000			
—	Pilot Pin (Diamond)	PP-1000K			

**MINIMUM RECOMENDED
DIE CLEARANCE .006**

MODEL H-2"

	CAT. NO.	THROAT DEPTH	HOLDER WIDTH	LENGTH A	LENGTH B	LENGTH C
8³/₈" SHUT HEIGHT	4H-2	4 ⁵ / ₈	1 ⁷ / ₈	7 ⁷ / ₈	1 ⁷ / ₈	—
	8H-2	8 ⁵ / ₈	1 ⁷ / ₈	11 ⁷ / ₈	5 ³ / ₈	—
	12H-2	12 ⁵ / ₈	1 ⁷ / ₈	15 ⁷ / ₈	5 ⁷ / ₈	3
3¹/₂" DIE HEIGHT	18H-2	18 ⁵ / ₈	1 ⁷ / ₈	21 ⁷ / ₈	5 ⁷ / ₈	5 ³ / ₈
	24H-2	24 ⁵ / ₈	2	27 ⁷ / ₈	5 ⁷ / ₈	5 ³ / ₈

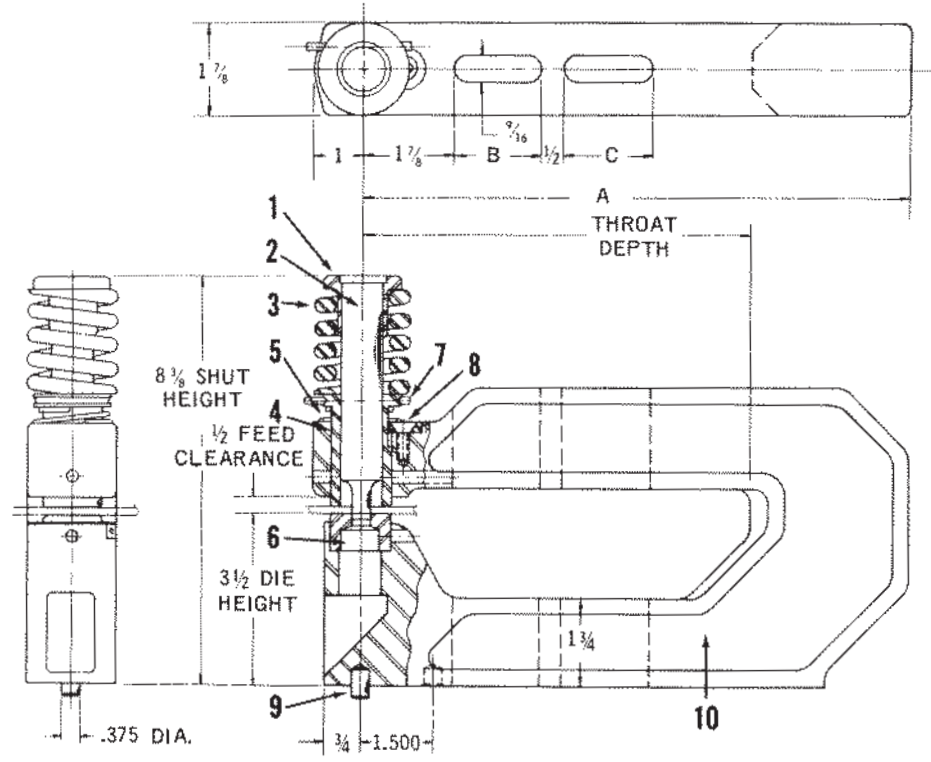
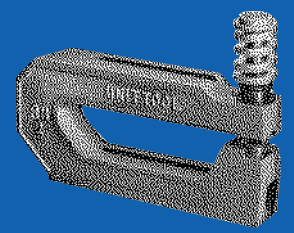

MIN. PUNCH SIZE .250

MAX. PUNCH SIZE .875

MAX. MATERIAL THICKNESS 1/4"

ITEM NO.	DESCRIPTION	CATALOG NO.	ITEM NO.	DESCRIPTION	CATALOG NO.
1	Punch Head	HPH-207	10	(1) Holder 4" Throat	4H 2C
2	Punch (Without Head)	HP-202		(1) Holder 8" Throat	8H 2C
—	Shaped Punch & Head Ass'y.	HPA-202K		(1) Holder 12" Throat	12H 2C
—	Punch & Head Ass'y.	HPA-202A		(1) Holder 18" Throat	18H 2C
3	Stripper Spring	HSS-205	11	Conversion Kit	HCK-200
4	Guide (Not Keyed)	HG-204	(1) Includes Pilot Pin & Guide Retainer		
—	Keyed Guide	HG-204K			
5	Lifter Spring	HLS-206	MINIMUM RECOMENDED DIE CLEARANCE .006		
6	Die Button	HD-203			
—	Shaped Die	HD-203K			
7	Punch Retainer	PR-100			
8	Guide Retainer	GR-300			
9	Pilot Pin	PP-1000			
—	Pilot Pin (Diamond)	PP-1000K			

MODEL H-2 1/2"

	CAT. NO.	THROAT DEPTH	HOLDER WIDTH	LENGTH A	LENGTH B	LENGTH C
8 3/8" SHUT HEIGHT	4H-2 1/2	4 5/8	2 1/2	7 7/8	1 7/8	—
	8H-2 1/2	8 5/8	2 1/2	11 7/8	5 3/8	—
	12H-2 1/2	12 5/8	2 1/2	15 7/8	5 7/8	3
3 1/2" DIE HEIGHT	18H-2 1/2	18 5/8	2 1/2	21 7/8	5 7/8	5 3/8
	24H-2 1/2	24 5/8	2 1/2	27 7/8	5 7/8	5 3/8

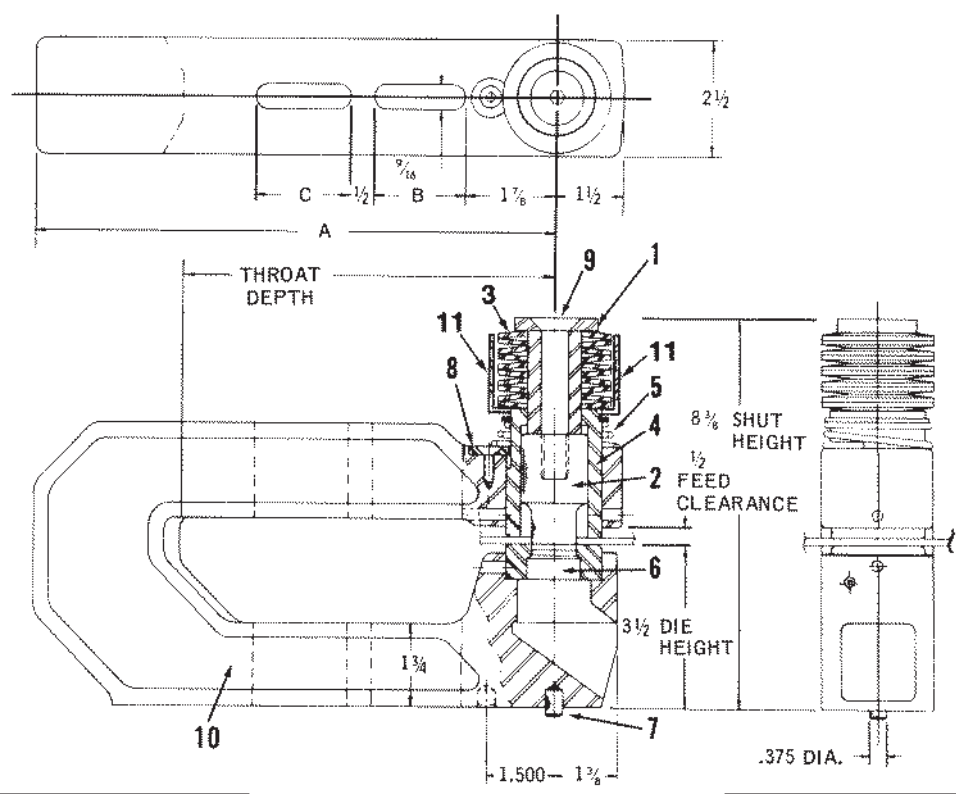
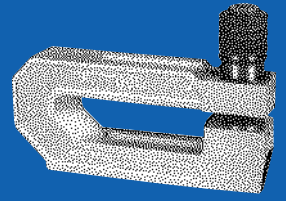

MIN. PUNCH SIZE .500

MAX. PUNCH SIZE 1.500

MAX. MATERIAL THICKNESS 1/4"

ITEM NO.	DESCRIPTION	CATALOG NO.	ITEM NO.	DESCRIPTION	CATALOG NO.
1	Punch Head	HPH-257 A	10	(1) Holder 4" Throat	4H 2 1/2 C
2	Punch	HP-252		(1) Holder 8" Throat	8H 2 1/2 C
—	Shaped Punch	HP-252K		(1) Holder 12" Throat	12H 2 1/2 C
3	Stripper Spring (10 per set)	HSS-255		(1) Holder 18" Throat	18H 2 1/2 C
4	Guide	HG-254	11	(2) Spring Guard	SG-250
—	Keyed Guide	HG-254K	12	Conversion Kit	HCK-250
5	Lifter Spring	HLS-256	(1) Includes Pilot Pin & Guide Retainer (2) Optional		
6	Die Button	HD-253			
—	Shaped Die	HD-253K	MINIMUM RECOMENDED DIE CLEARANCE .006		
7	Pilot Pin	PP-1000			
—	Pilot Pin (Diamond)	PP-1000K			
8	Guide Retainer	GR-300			
9	Punch Screw	PS-259			

MODEL H-3"

	CAT. NO.	THROAT DEPTH	HOLDER WIDTH	LENGTH A	LENGTH B	LENGTH C
8 ³ / ₈ " SHUT HEIGHT	8H-3	8 ⁵ / ₈	3	11 ⁷ / ₈	5	—
	12H-3	12 ⁵ / ₈	3	15 ⁷ / ₈	5 ⁷ / ₈	—
3 ¹ / ₂ " DIE HEIGHT	18H-3	18 ⁵ / ₈	3	21 ⁷ / ₈	5 ⁷ / ₈	5

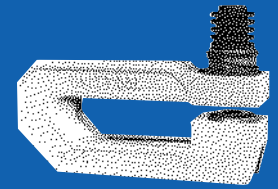

THIS UNIT IS KEYPED FOR BOTH ROUND & SHAPED PUNCHES & DIES

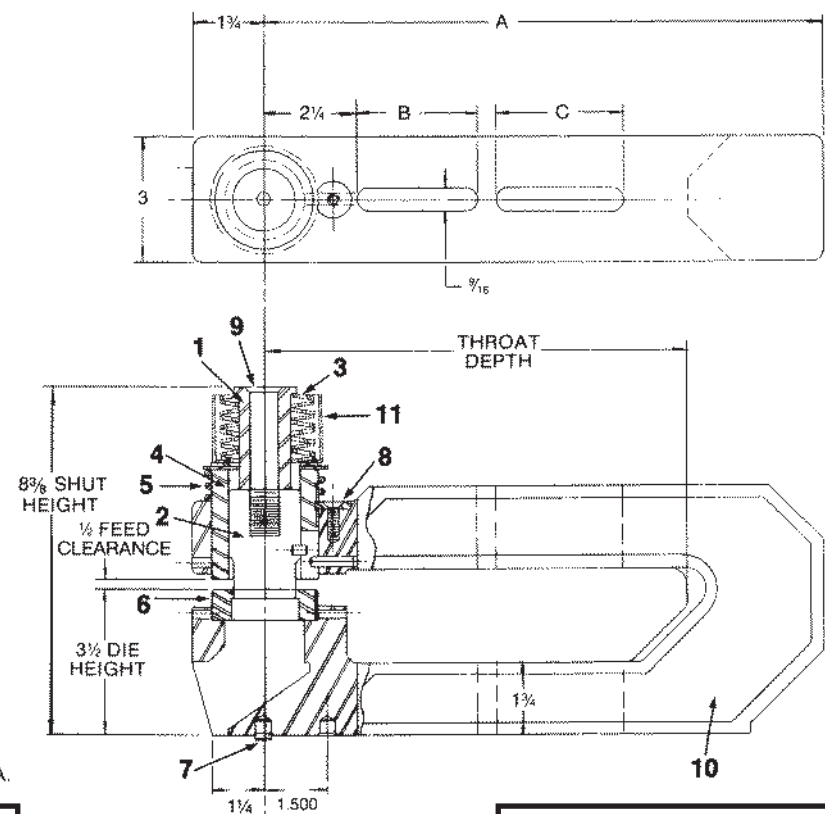
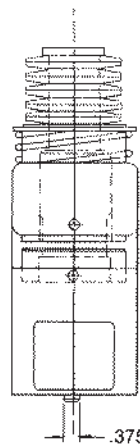

MIN. PUNCH SIZE .750

MAX. PUNCH SIZE 1.750

MAX. MATERIAL THICKNESS 1/4"

ITEM NO.	DESCRIPTION	CATALOG NO.	ITEM NO.	DESCRIPTION	CATALOG NO.
1	Punch Head	HPH-257 A	10	(1) Holder 8" Throat	8H 3CK
2	Punch	HP-302		(1) Holder 12" Throat	12H 3CK
—	Shaped Punch	HP-302K		(1) Holder 18" Throat	18H 3CK
3	Stripper Spring (10 per set)	HSS-255	11	(2) Spring Guard	SG-250
4	Guide	HG-304		(1) Includes Pilot Pin & Guide Retainer	
—	Keyed Guide	HG-304K		(2) Optional	
5	Lifter Spring	HLS-306			
6	Die Button	HD-303			
—	Shaped Die	HD-303K			
7	Pilot Pin	PP-1000			
—	Pilot Pin (Diamond)	PP-1000K			
8	Guide Retainer	GR-300			
9	Punch Screw	PS-259			

**MINIMUM RECOMENDED
DIE CLEARANCE .006**

MODEL H-3 1/2"

	CAT. NO.	THROAT DEPTH	HOLDER WIDTH	LENGTH A	LENGTH B	LENGTH C
8 3/8" SHUT HEIGHT	8H-3 1/2	8 5/8	3 1/2	12 1/8	3 1/2	—
	12H-3 1/2	12 5/8	3 1/2	16 1/8	5 1/2	—
3 1/2" DIE HEIGHT	18H-3 1/2	18 5/8	3 1/2	22 1/8	5 1/2	—
	24H-3 1/2	24 5/8	3 1/2	29 1/8	5 1/2	—

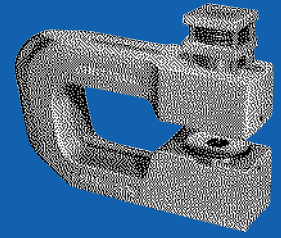

THIS UNIT IS KEYPED FOR BOTH ROUND & SHAPED PUNCHES & DIES

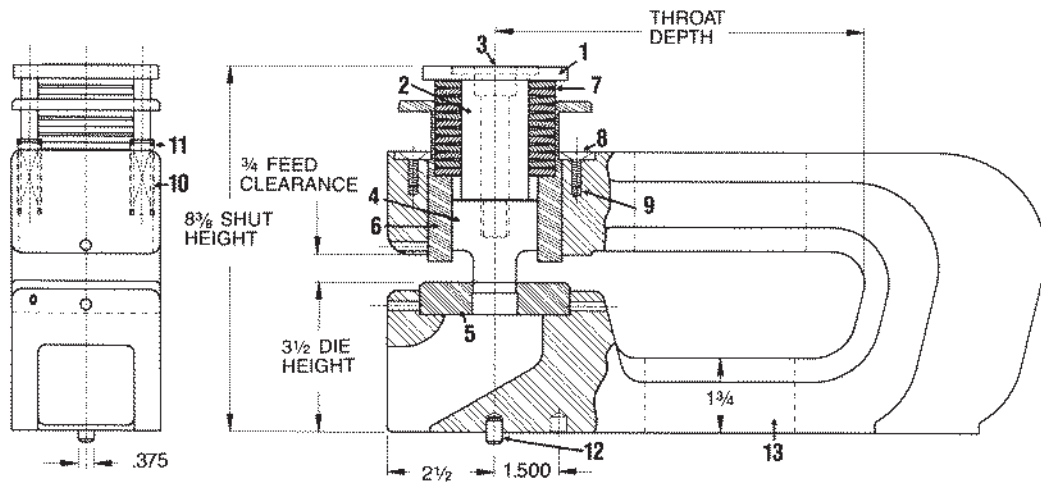
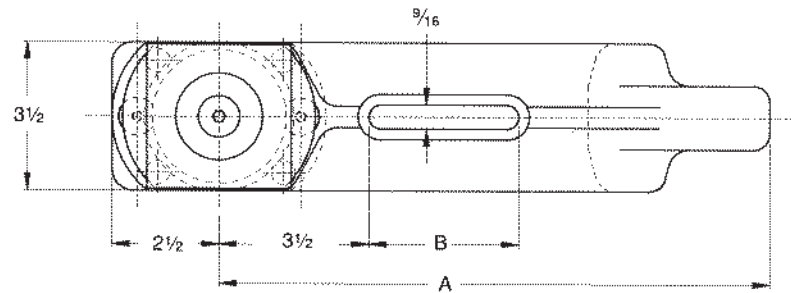

MAX. PUNCH SIZE & MATERIAL THICKNESS — 2" DIAM. IN 1/4" THICKNESS 1 1/4" DIAM. IN 1/2" THICKNESS
1 5/8" DIAM. IN 3/8" THICKNESS

ITEM NO.	DESCRIPTION	CATALOG NO.	ITEM NO.	DESCRIPTION	CATALOG NO.
1	Punch Head	HPH-357	12	Pilot Pin	PP-1000
2	Punch Driver	D-358	—	Pilot Pin (Diamond)	PP-1000K
3	Punch Screw	5/8-11x3 S.H.C.S.	13	(1) Holder 8" Throat	8H 3 1/2CK
4	Punch	HP-352		(1) Holder 12" Throat	12H 3 1/2CK
—	Shaped Punch	HP-352K		(1) Holder 18" Throat	18H 3 1/2CK
5	Die	HD-353	14	Guide or Die Key	GK-100
—	Shaped Die	HD-353K			
6	Guide (Keyed)	HG-354K			
7	Stripper Spring Set (12 per set)	HSS-355			
8	Guide Retainer	GR-300			
9	Retainer Plate Screw	1/4-20x5/8 B.H.C.S.			
10	Lifter Spring	HLS-356			
11	Lifter Pins	HLP-356-1			

MINIMUM RECOMENDED DIE CLEARANCE .012

MODEL H-5^{3/4}"

	CAT. NO.	THROAT DEPTH	HOLDER WIDTH	LENGTH A	LENGTH B	LENGTH C
8 ^{3/8} " SHUT HEIGHT	8H-5 ^{3/4}	8 ⁵ / ₈	5 ³ / ₄	13 ¹ / ₈	3	—
	12H-5 ^{3/4}	12 ⁵ / ₈	5 ³ / ₄	17 ¹ / ₈	5 ¹ / ₂	—
3 ¹ / ₂ " DIE HEIGHT	18H-5 ^{3/4}	18 ⁵ / ₈	5 ³ / ₄	23 ¹ / ₈	5 ¹ / ₂	—
	24H-5 ^{3/4}	24 ⁵ / ₈	5 ³ / ₄	29 ¹ / ₈	5 ¹ / ₂	—

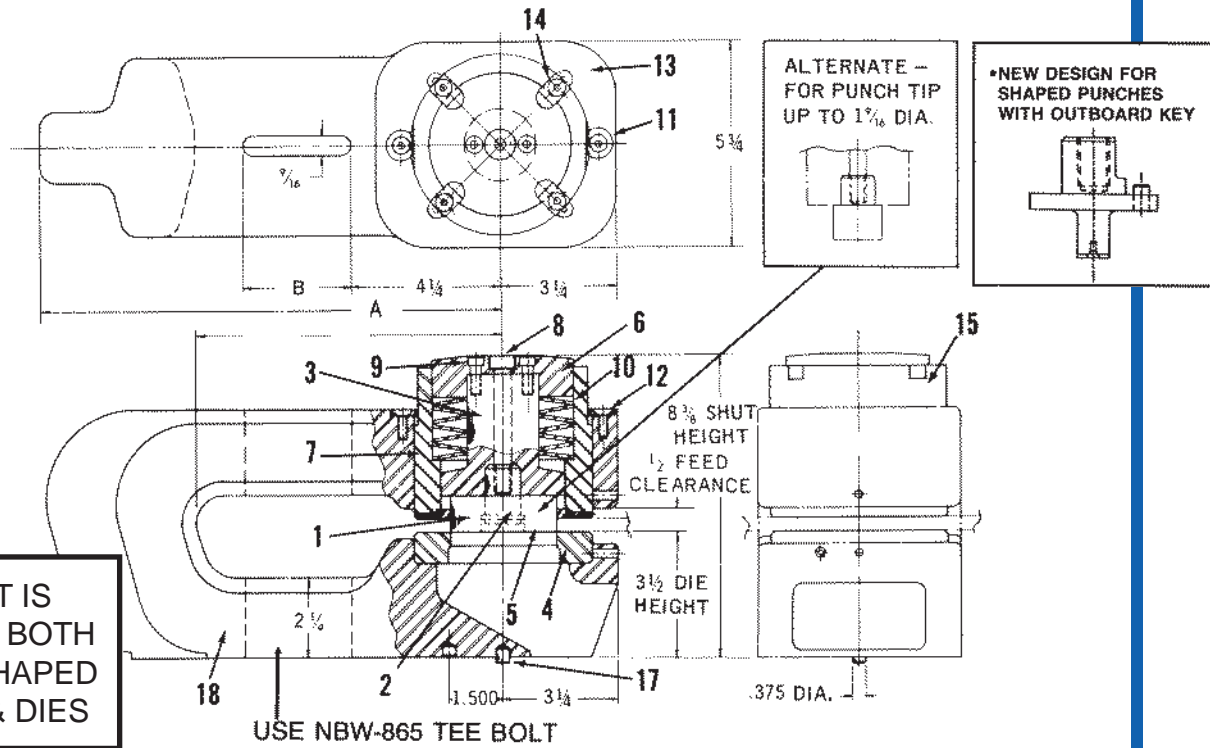
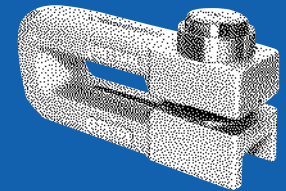

THIS UNIT IS KEYED FOR BOTH ROUND & SHAPED PUNCHES & DIES

MAX. PUNCH SIZE & MATERIAL THICKNESS – 3¹/₂" DIAM. IN 3¹/₁₆" THICKNESS – 3" DIAM. IN 1¹/₄" THICKNESS

ITEM NO.	DESCRIPTION	CATALOG NO.	ITEM NO.	DESCRIPTION	CATALOG NO.
1	Punch-1 ⁵ / ₁₆ " thru 1 ⁹ / ₁₆ "	MP-502A	13	Lifter Pads-(4 req'd.)	LP-576-1
-	Shaped Punch	MP-502AK	14	Lifter Pad Screws-(4 req'd.)	⁵ / ₁₆ -18x ⁵ / ₈ B.H.C.S.
1	Punch-1 ⁵ / ₈ thru 2 ¹ / ₄	MP-502B	15	Lifter Springs-(4 req'd.)	HLS-356
1	Punch-2 ⁵ / ₁₆ thru 2 ⁷ / ₈	MP-502C	16	Stripper Plate Screws-(4 req'd.)	10-32x ¹ / ₄ S.S.S.
-	Shaped Punch	MP-502CK	17	Pilot Pin	PP-1000
1	Punch-2 ¹⁵ / ₁₆ thru 3 ¹ / ₂	MP-502D	-	Pilot Pin Diamond	PP-1000K
-	Shaped Punch	MP-502DK	18	(¹) Holder 8" Throat	8H 5 ³ / ₄ CK
2	Punch Tip Retainer	PR-500	(¹) Holder 12" Throat	12H 5 ³ / ₄ CK	
3	Punch Driver	PD-579	(¹) Holder 18" Throat	18H 5 ³ / ₄ CK	
4	Die	HD-603	19	Guide or Die Key	GK-100
-	Shaped Die	HD-603K	(1) Includes Pilot Pin & Guide Retainer		
5	Stripper Plate (Optional)	MSP-509			
-	Stripper Plate (Optional)	HSP-509K			
6	Punch Cap	HPC-577			
7	Guide (Keyed)	HG-574K			
8	Punch Screw	¹ / ₂ -13x3 S.H.C.S.			
9	Punch Cap Retainer Screw	⁵ / ₁₆ -18x ³ / ₄ S.H.C.S.			
10	Stripper Spring Set (7 per set)	HSS-575			
11	Retainer Plate	GR-300			
12	Retainer Plate Screw	¹ / ₄ -20x ⁵ / ₈ B.H.C.S.			

MINIMUM RECOMENDED
DIE CLEARANCE .012

* IF USING OLD DESIGN PUNCH DRIVER
CONTACT FACTORY FOR MODIFICATION DETAILS

MODEL H-8"

	CAT. NO.	THROAT DEPTH	HOLDER WIDTH	LENGTH A	LENGTH B	LENGTH C
8³/₈" SHUT HEIGHT	14H-8	14 ⁵ / ₈	8"	20	8 1/2	—
3¹/₂" DIE HEIGHT	18H-8	18 ⁵ / ₈	8"	24	12 1/2	—
	24H-8	24 ⁵ / ₈	8"	30 1/2	12 1/2	—

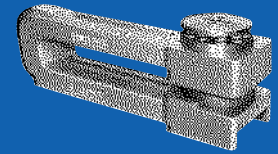

**EXCLUSIVE
WITH
UNITTOOL!**

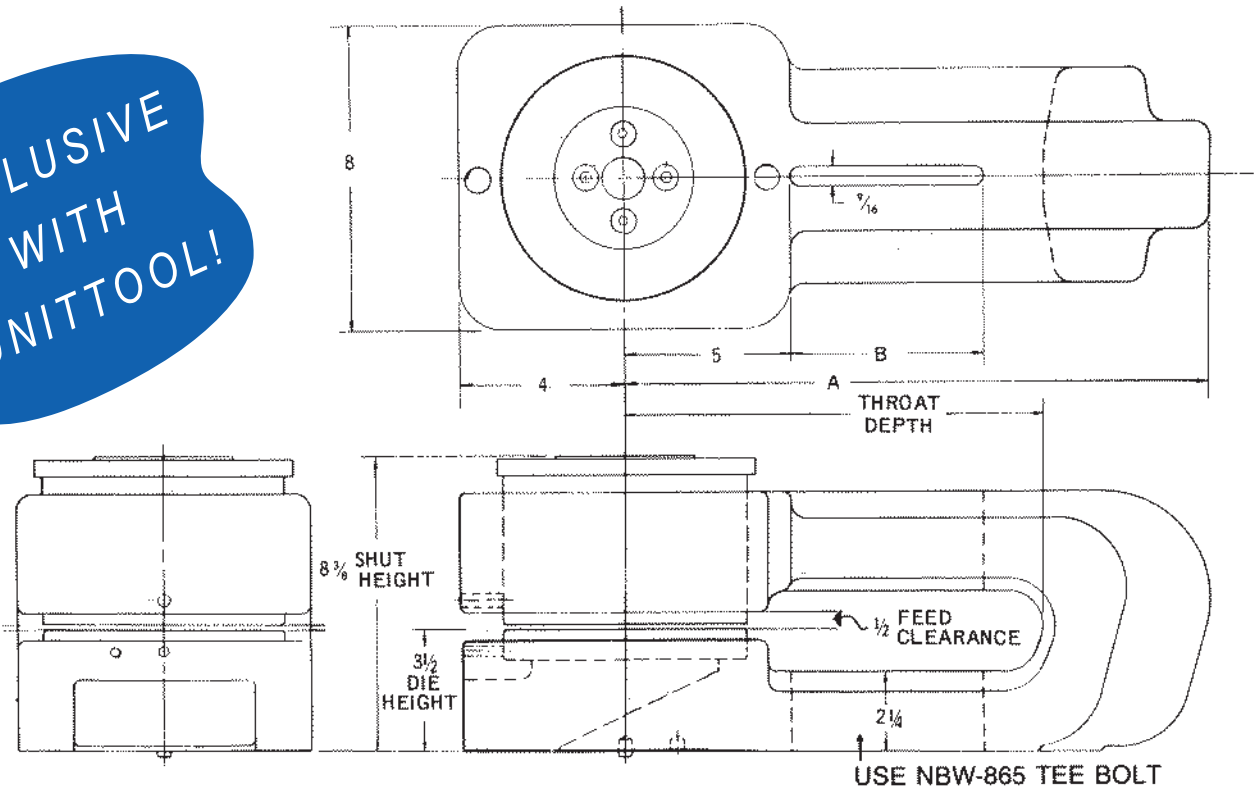

MAX. PUNCH SIZE & MATERIAL THICKNESS – 5" DIAM. IN 1/8" THICKNESS 3" DIAM. IN 1/4" THICKNESS
4" DIAM. IN 3/16" THICKNESS

ITEM NO.	DESCRIPTION	CATALOG NO.
1	Punch	HP-802
2	Die	HD-803
3	Guide	HG-804K
4	Punch Driver	PD-808
5	Stripper Spring (10 required)	HSS-805
6	Lifter spring (4 required)	HLS-806
7	Punch Plate	HPH-807
8	Stripper Plate	HSP-809
9	Punch Retainer	HPR-800
10	Punch Screw	⁵ / ₈ -11x3 S.H.C.S.
11	Pilot Pin	PP-1000
12	(¹) Holder 14" Throat	14H8CK
	(¹) Holder 18" Throat	18H8CK
	(¹) Includes Pilot Pin	

Unittool's extended range of hole punching units makes it possible to pierce up to 5" diameter holes with the popular 8³/₈" shut height and 3¹/₂" die height. Shaped holes with a dimension not greater than 5" can also be pierced with this unit.

The holder is made from 80,000 pound tensile strength material. The punches and dies are manufactured from oil hardening tool steel and the punch guide is produced from a high-grade 4140 alloy steel.

Round punch and die sizes are available from 2¹/₂" diameter to 5" diameter. The punch is furnished with 1/16" shear to help reduce normal punching pressure.

**MINIMUM RECOMENDED
DIE CLEARANCE .012**

MODEL HP-1"

CAT. NO.	THROAT DEPTH	HOLDER WIDTH	LENGTH A	LENGTH B	LENGTH C
4HP-1	4 5/8"	1"	7 7/8"	1 7/8"	—
8HP-1	8 5/8"	1"	11 7/8"	5 3/8"	—
12HP-1	12 5/8"	1"	15 7/8"	5 7/8"	—

MODEL HA-1"

CAT. NO.	THROAT DEPTH	HOLDER WIDTH	LENGTH A	LENGTH B	LENGTH C
4HA-1	4 5/8"	1"	7 7/8"	1 7/8"	—
8HA-1	8 5/8"	1"	11 7/8"	5 3/8"	—
12HA-1	12 5/8"	1"	15 7/8"	5 7/8"	—

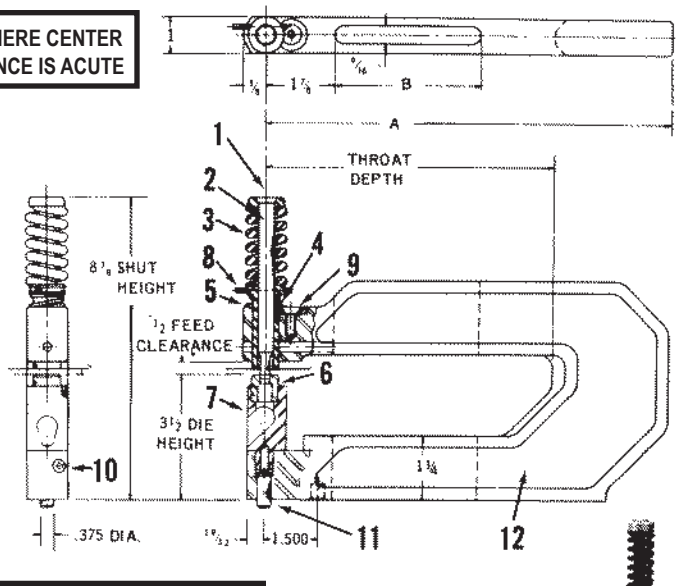
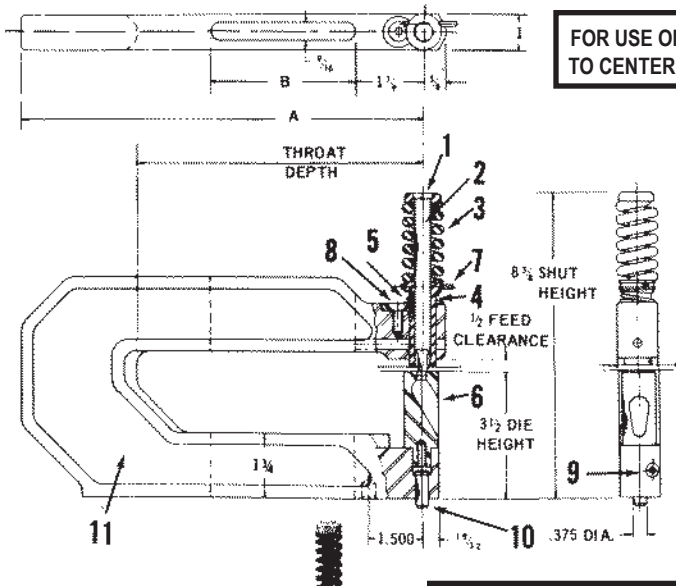

5/16" MAX. PUNCH SIZE FOR 1/4" THICK MATERIAL
7/16" MAX. PUNCH SIZE FOR 1/8" MATERIAL

MINIMUM RECOMENDED
DIE CLEARANCE .012

MODEL HP-1"			MODEL HA-1"		
ITEM NO.	DESCRIPTION	CATALOG NO.	ITEM NO.	DESCRIPTION	CATALOG NO.
1	Punch Head	HPH-107	1	Punch Head	HPH-107
2	Punch (Without Head)	HP-122	2	Punch (Without Head)	HP-122
—	Shaped Punch & Head Ass'y.	HPA-102K	—	Shaped Punch & Head Ass'y.	HPA-102K
—	Punch & Head Ass'y.	HPA-102A	—	Punch & Head Ass'y.	HPA-102A
3	Stripper Spring	HSS-105	3	Stripper Spring	HSS-105
4	Guide (Not Keyed)	HG-104	4	Guide (Not Keyed)	HG-104
—	Keyed Guide	HG-104K	—	Keyed Guide	HG-104K
5	Lifter Spring	HLS-106	5	Lifter Spring	HLS-106
6	Pedestal Die	HPD-123	6	Die Button	HD-123
—	Shaped Pedestal Die	HPD-123K	—	Shaped Die	HD-123K
7	Punch Retainer	PR-100	7	Die Adapter	HDA-108
8	Guide Retainer	GR-300	—	Keyed Die Adapter	HDA-108K
9	Die Retainer Screw	10-32x3/4 S.H.C.S.	8	Punch Retainer	PR-100
10	Pilot Pin	PP-1200	9	Guide Retainer	GR-300
—	Pilot Pin (Diamond)	PP-1000K	10	Die Retainer Screw	10-32x3/4 S.H.C.S.
11	(1) Holder 4" Throat	4HP 1-C	11	Pilot Pin	PP-1200
	(1) Holder 8" Throat	8HP 1-C	—	Pilot Pin (Diamond)	PP-1000K
	(1) Holder 12" Throat	12HP 1-C	12	(1) Holder 4" Throat	4HP 1-C
12	Conversion Kit	HPCK-100		(1) Holder 8" Throat	8HP 1-C
				(1) Holder 12" Throat	12HP 1-C
			13	Conversion Kit	HPCK-100

(1) Includes Pilot Pin & Guide Retainer

(1) Includes Pilot Pin & Guide Retainer

MODEL HP-1 1/4"

CAT. NO.	THROAT DEPTH	HOLDER WIDTH	LENGTH A	LENGTH B	LENGTH C
4HP-1 1/4	4 5/8"	1 1/4"	7 7/8"	1 7/8"	—
8HP-1 1/4	8 5/8"	1 1/4"	11 7/8"	5 3/8"	—
12HP-1 1/4	12 5/8"	1 1/4"	15 7/8"	5 7/8"	3

MODEL HA-1 1/4"

CAT. NO.	THROAT DEPTH	HOLDER WIDTH	LENGTH A	LENGTH B	LENGTH C
4HA-1 1/4	4 5/8"	1 1/4"	7 7/8"	1 7/8"	—
8HA-1 1/4	8 5/8"	1 1/4"	11 7/8"	5 3/8"	—
12HA-1 1/4	12 5/8"	1 1/4"	15 7/8"	5 7/8"	3

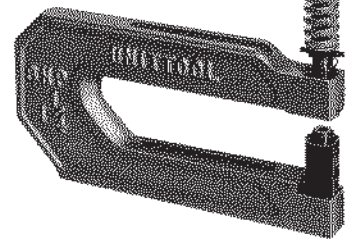
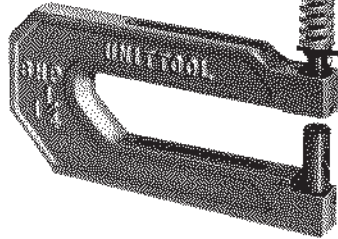
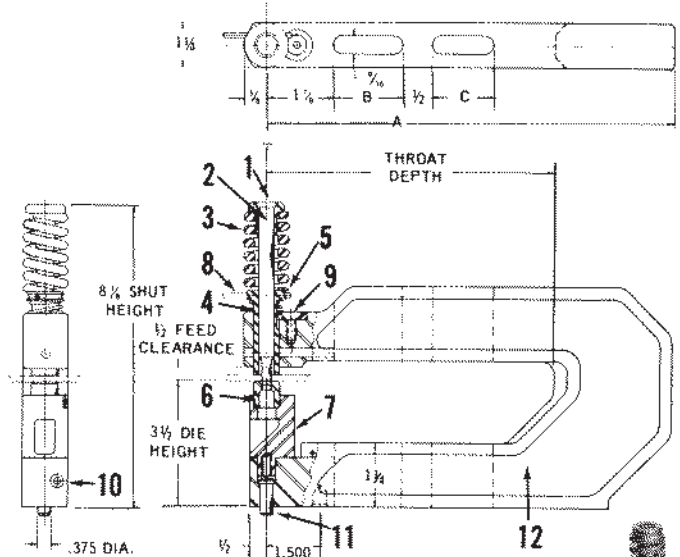
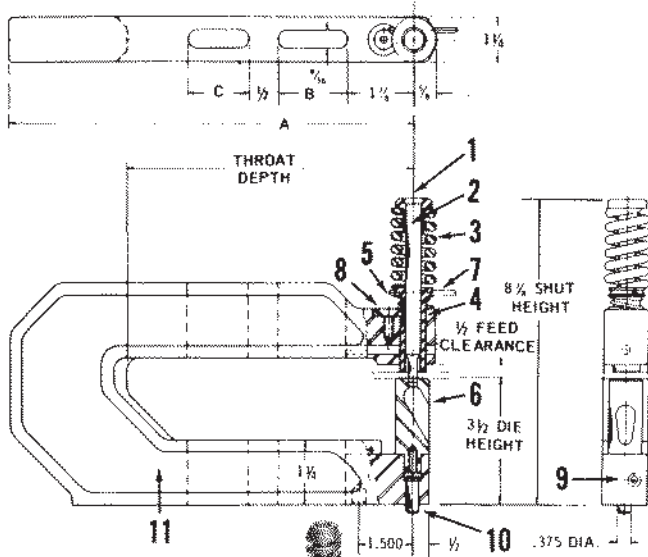

MAX. MATERIAL THICKNESS 1/4"
MIN. PUNCH SIZE .093 MAX. PUNCH SIZE .4375

MINIMUM RECOMENDED
DIE CLEARANCE .012

MODEL HP-1 1/4"			MODEL HA-1 1/4"		
ITEM NO.	DESCRIPTION	CATALOG NO.	ITEM NO.	DESCRIPTION	CATALOG NO.
1	Punch Head	HPH-127	1	Punch Head	HPH-127
2	Punch (Without Head)	HP-122	2	Punch (Without Head)	HP-122
—	Shaped Punch & Head Ass'y.	HPA-122K	—	Shaped Punch & Head Ass'y.	HPA-122K
—	Punch & Head Ass'y.	HPA-122A	—	Punch & Head Ass'y.	HPA-122A
3	Stripper Spring	HSS-125	3	Stripper Spring	HSS-125
4	Guide (Not Keyed)	HG-124	4	Guide (Not Keyed)	HG-124
—	Keyed Guide	HG-124K	—	Keyed Guide	HG-124K
5	Lifter Spring	HLS-126	5	Lifter Spring	HLS-126
6	Pedestal Die	HPD-123	6	Die Button	HD-123
—	Shaped Pedestal Die	HPD-123K	—	Shaped Die	HD-123K
7	Punch Retainer	PR-100	7	Die Adapter	HDA-128
8	Guide Retainer	GR-300	—	Keyed Die Adapter	HDA-128K
9	Die Retainer Screw	10-32x3/4 S.H.C.S.	8	Punch Retainer	PR-100
10	Pilot Pin	PP-1200	9	Guide Retainer	GR-300
—	Pilot Pin (Diamond)	PP-1000K	10	Die Retainer Screw	10-32x3/4 S.H.C.S.
11	(1) Holder 4" Throat	4HP 1 1/4C	11	Pilot Pin	PP-1200
	(1) Holder 8" Throat	8HP 1 1/4C	—	Pilot Pin (Diamond)	PP-1000K
	(1) Holder 12" Throat	12HP 1 1/4C	12	(1) Holder 4" Throat	4HP 1 1/4C
12	Conversion Kit	HPCK-125		(1) Holder 8" Throat	8HP 1 1/4C
				(1) Holder 12" Throat	12HP 1 1/4C
			13	Conversion Kit	HPCK-125

(1) Includes Pilot Pin & Guide Retainer

(1) Includes Pilot Pin & Guide Retainer

MODEL HP-1 1/2"

CAT. NO.	THROAT DEPTH	HOLDER WIDTH	LENGTH A	LENGTH B	LENGTH C
4HP-1 1/2	4 5/8"	1 1/2"	7 7/8"	1 7/8"	—
8HP-1 1/2	8 5/8"	1 1/2"	11 7/8"	5 3/8"	—
12HP-1 1/2	12 5/8"	1 1/2"	15 7/8"	5 7/8"	3
18HP-1 1/2	18 5/8"	1 1/2"	21 7/8"	5 7/8"	5 3/8
24HP-1 1/2	24 5/8"	1 1/2"	27 7/8"	5 7/8"	5 3/8

MODEL HA-1 1/2"

CAT. NO.	THROAT DEPTH	HOLDER WIDTH	LENGTH A	LENGTH B	LENGTH C
4HA-1 1/2	4 5/8"	1 1/2"	7 7/8"	1 7/8"	—
8HA-1 1/2	8 5/8"	1 1/2"	11 7/8"	5 3/8"	—
12HA-1 1/2	12 5/8"	1 1/2"	15 7/8"	5 7/8"	3
18HA-1 1/2	18 5/8"	1 1/2"	21 7/8"	5 7/8"	5 3/8
24HA-1 1/2	24 5/8"	1 1/2"	27 7/8"	5 7/8"	5 3/8

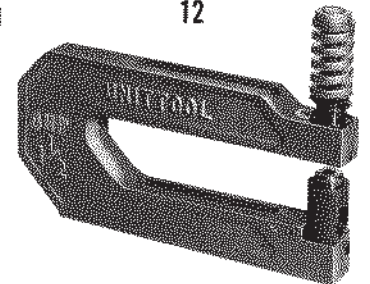
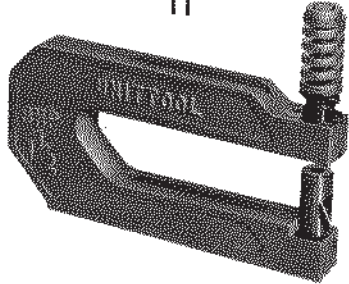
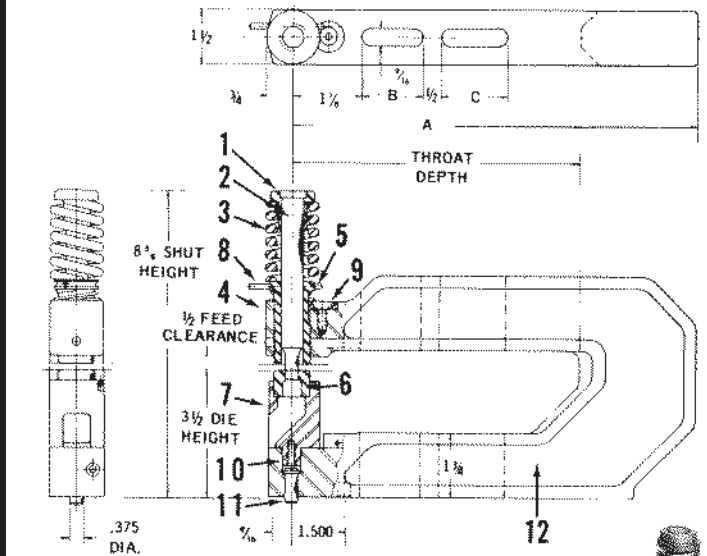
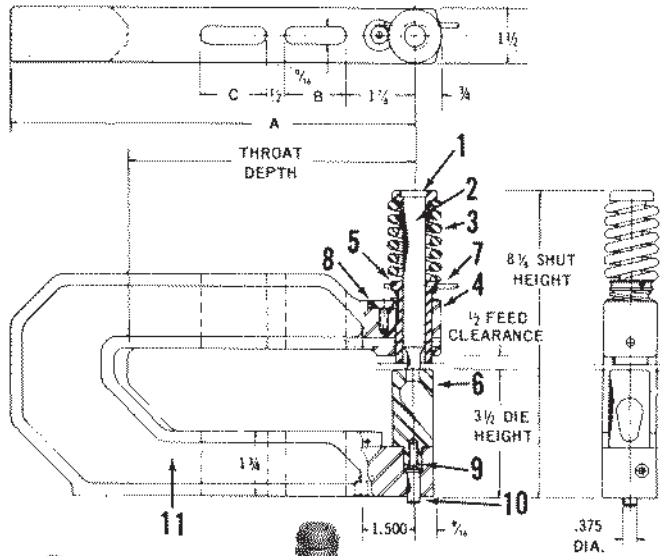

MAX. MATERIAL THICKNESS 1/4"
 MIN. PUNCH SIZE .1875
 MAX. PUNCH SIZE .625

MINIMUM RECOMENDED
 DIE CLEARANCE .012

MODEL HP-1 1/2"			MODEL HA-1 1/2"		
ITEM NO.	DESCRIPTION	CATALOG NO.	ITEM NO.	DESCRIPTION	CATALOG NO.
1	Punch Head	HPH-157	1	Punch Head	HPH-157
2	Punch (Without Head)	HP-152	2	Punch (Without Head)	HP-152
—	Shaped Punch & Head Ass'y.	HPA-152K	—	Shaped Punch & Head Ass'y.	HPA-152K
—	Punch & Head Ass'y.	HPA-152A	—	Punch & Head Ass'y.	HPA-152A
3	Stripper Spring	HSS-155	3	Stripper Spring	HSS-155
4	Guide (Not Keyed)	HG-154	4	Guide (Not Keyed)	HG-154
—	Keyed Guide	HG-154K	—	Keyed Guide	HG-154K
5	Lifter Spring	HLS-156	5	Lifter Spring	HLS-156
6	Pedestal Die	HPD-153	6	Die Button	HD-153
—	Shaped Pedestal Die	HPD-153K	—	Shaped Die	HD-153K
7	Punch Retainer	PR-100	7	Die Adapter	HDA-158
8	Guide Retainer	GR-300	—	Keyed Die Adapter	HDA-158K
9	Die Retainer Screw	1/4-20x3/4 S.H.C.S.	8	Punch Retainer	PR-100
10	Pilot Pin	PP-1200	9	Guide Retainer	GR-300
—	Pilot Pin (Diamond)	PP-1000K	10	Die Retainer Screw	1/4-20x3/4 S.H.C.S.
11	(1) Holder 4" Throat	4HP 1 1/2C	11	Pilot Pin	PP-1200
	(1) Holder 8" Throat	8HP 1 1/2C	—	Pilot Pin (Diamond)	PP-1000K
	(1) Holder 12" Throat	12HP 1 1/2C	12	(1) Holder 4" Throat	4HP 1 1/2C
	(1) Holder 18" Throat	18HP 1 1/2C		(1) Holder 8" Throat	8HP 1 1/2C
12	Conversion Kit	HPCK-150		(1) Holder 12" Throat	12HP 1 1/2C
				(1) Holder 18" Throat	18HP 1 1/2C
			13	Conversion Kit	HPCK-150

(1) Includes Pilot Pin & Guide Retainer

(1) Includes Pilot Pin & Guide Retainer

MODEL HP-2"

CAT. NO.	THROAT DEPTH	HOLDER WIDTH	LENGTH A	LENGTH B	LENGTH C
4HP-2	4 5/8"	1 7/8"	7 7/8"	1 7/8"	—
8HP-2	8 5/8"	1 7/8"	11 7/8"	5 3/8"	—
12HP-2	12 5/8"	1 7/8"	15 7/8"	5 7/8"	3
18HP-2	18 5/8"	1 7/8"	21 7/8"	5 7/8"	5 3/8"
24HP-2	24 5/8"	2	27 7/8"	5 7/8"	5 3/8"

MODEL HA-2"

CAT. NO.	THROAT DEPTH	HOLDER WIDTH	LENGTH A	LENGTH B	LENGTH C
4HA-2	4 5/8"	1 7/8"	7 7/8"	1 7/8"	—
8HA-2	8 5/8"	1 7/8"	11 7/8"	5 3/8"	—
12HA-2	12 5/8"	1 7/8"	15 7/8"	5 7/8"	3
18HA-2	18 5/8"	1 7/8"	21 7/8"	5 7/8"	5 3/8"
24HA-2	24 5/8"	2	27 7/8"	5 7/8"	5 3/8"

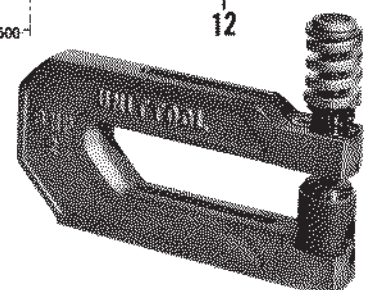
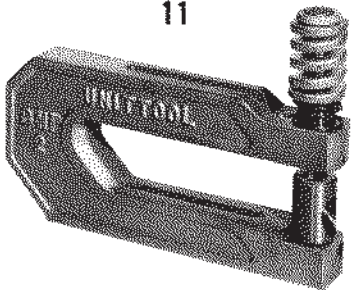
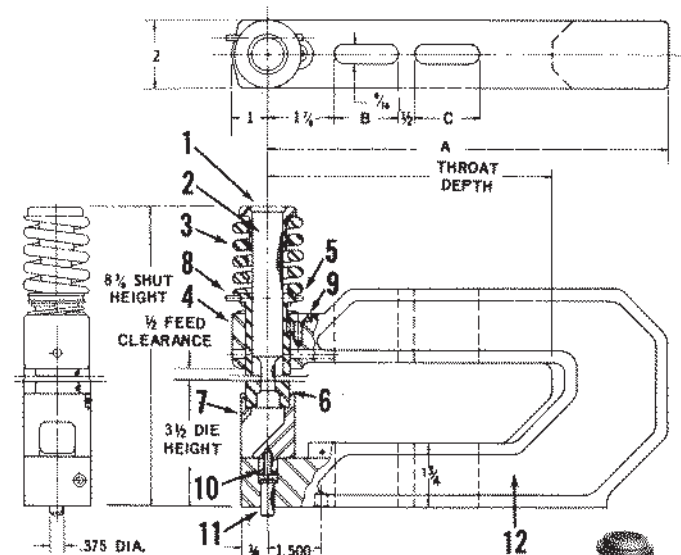
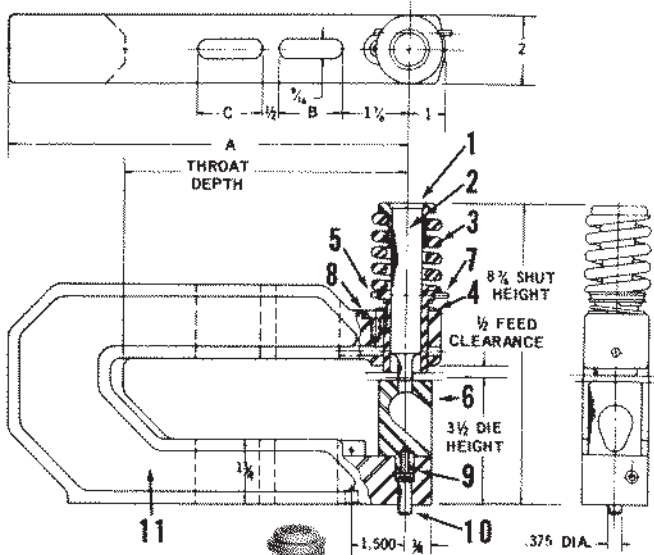

MAX. MATERIAL THICKNESS 1/4"
MIN. PUNCH SIZE .250
MAX. PUNCH SIZE .875

MINIMUM RECOMENDED
DIE CLEARANCE .012

MODEL HP-2"			MODEL HA-2"		
ITEM NO.	DESCRIPTION	CATALOG NO.	ITEM NO.	DESCRIPTION	CATALOG NO.
1	Punch Head	HPH-207	1	Punch Head	HPH-207
2	Punch (Without Head)	HP-202	2	Punch (Without Head)	HP-202
—	Shaped Punch & Head Ass'y.	HPA-202K	—	Shaped Punch & Head Ass'y.	HPA-202K
—	Punch & Head Ass'y.	HPA-202A	—	Punch & Head Ass'y.	HPA-202A
3	Stripper Spring	HSS-205	3	Stripper Spring	HSS-205
4	Guide (Not Keyed)	HG-204	4	Guide (Not Keyed)	HG-204
—	Keyed Guide	HG-204K	—	Keyed Guide	HG-204K
5	Lifter Spring	HLS-206	5	Lifter Spring	HLS-206
6	Pedestal Die	HPD-203	6	Die Button	HD-203
—	Shaped Pedestal Die	HPD-203K	—	Shaped Die	HD-203K
7	Punch Retainer	PR-100	7	Die Adapter	HDA-208
8	Guide Retainer	GR-300	—	Keyed Die Adapter	HDA-208K
9	Die Retainer Screw	5/16-18x1" S.H.C.S.	8	Punch Retainer	PR-100
10	Pilot Pin	PP-1200	9	Guide Retainer	GR-300
—	Pilot Pin (Diamond)	PP-1000K	10	Die Retainer Screw	5/16-18x1" S.H.C.S.
11	(1) Holder 4" Throat	4HP 2C	11	Pilot Pin	PP-1200
	(1) Holder 8" Throat	8HP 2C	—	Pilot Pin (Diamond)	PP-1000K
	(1) Holder 12" Throat	12HP 2C	12	(1) Holder 4" Throat	4HP 2C
	(1) Holder 18" Throat	18HP 2C		(1) Holder 8" Throat	8HP 2C
12	Conversion Kit	HPCK-200		(1) Holder 12" Throat	12HP 2C
				(1) Holder 18" Throat	18HP 2C
			13	Conversion Kit	HPCK-200

(1) Includes Pilot Pin & Guide Retainer

(1) Includes Pilot Pin & Guide Retainer

MODEL HP-2 1/2"

	CAT. NO.	THROAT DEPTH	HOLDER WIDTH	LENGTH A	LENGTH B	LENGTH C
8 3/8" SHUT HEIGHT	4HP-2 1/2	4 5/8	2 1/2	7 7/8	1 7/8	—
	8HP-2 1/2	8 5/8	2 1/2	11 7/8	5 3/8	—
3 1/2" DIE HEIGHT	12HP-2 1/2	12 5/8	2 1/2	15 7/8	5 7/8	3

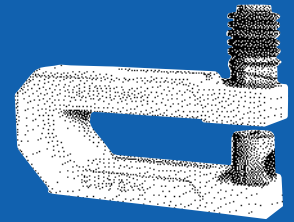

OPTIONAL HPD-253-1

Special Oversized Pedestal Die - to be used with Punches over 1.250 Dia.

PRICE ON APPLICATION

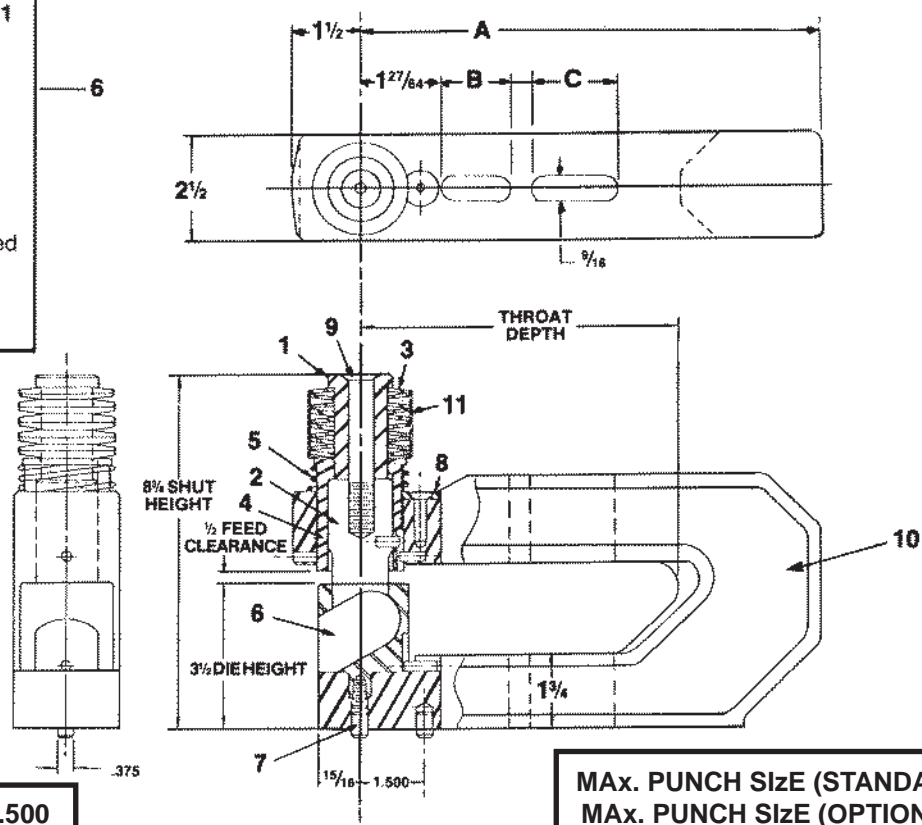

MIN. PUNCH SIZE .500

Max. PUNCH Size (STANDARD) 1.250
Max. PUNCH Size (OPTIONAL) 1.500

Max. MATERIAL THICKNESS 1/4"

ITEM NO.	DESCRIPTION	CATALOG NO.	ITEM NO.	DESCRIPTION	CATALOG NO.
1	Punch Head	HPH-257 A	9	Punch Screw	PS-259
2	Punch	HP-252	10	(1) Holder 4" Throat	4HP-2 1/2C
—	Shaped Punch	HP-252K		(1) Holder 8" Throat	8HP-2 1/2C
3	Stripper Spring (10 per set)	HSS-255		(1) Holder 12" Throat	12HP-2 1/2C
4	Guide	HG-254	11	(2) Spring Guard	SG-250
—	Keyed Guide	HG-254K	(1) Includes Pilot Pin & Guide Retainer		
5	Lifter Spring	HLS-256	(2) Optional		
6	Pedestal Die	HPD-253	MINIMUM RECOMENDED DIE CLEARANCE .012		
—	Pedestal Die (Optional)	HPD-253-1			
—	Shaped Pedestal Die	HPD-253K			
7	Pilot Pin	PP-1000			
—	Pilot Pin (Diamond)	PP-1000K			
8	Guide Retainer	GR-300			

**PUNCH RANGE - .250 THRU 1.000 DIA.
MAX. MAT'L THICKNESS - 1/2" MILD STEEL**

MODEL
HH-2 1/2"

	CAT. NO.	THROAT DEPTH	HOLDER WIDTH	LENGTH A	LENGTH B	LENGTH C
8 3/8" SHUT HEIGHT	8HH-2 1/2	8 5/8	2 1/2	12 1/8	3 1/2	—
	12HH-2 1/2	12 5/8	2 1/2	16 1/8	5 1/2	—
3 1/2" DIE HEIGHT	18HH-2 1/2	18 5/8	2 1/2	22 1/8	5 1/2	5 1/2
	24HH-2 1/2	24 1/8	2 1/2	27 5/8	5 1/2	5 1/2

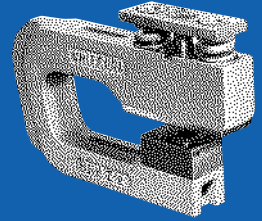

RECOMMENDED DIE CLEARANCE

Upto 1/16" Thick Material	— .008 Total
Over 1/16" thru 1/8" Thick Material	— .018 Total
Over 1/8" thru 3/16" Thick Material	— .028 Total
Over 3/16" thru 1/4" Thick Material	— .043 Total
Over 1/4" thru 3/8" Thick Material	— .075 Total
Over 3/8" thru 1/2" Thick Material	— .100 Total

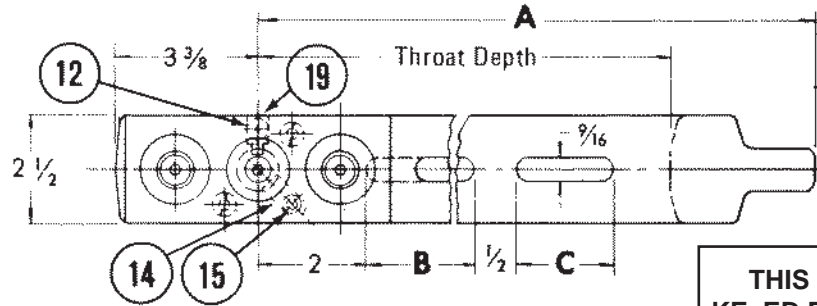

**THIS UNIT IS
KEYED FOR BOTH
ROUND & SHAPED
PUNCHES & DIES**

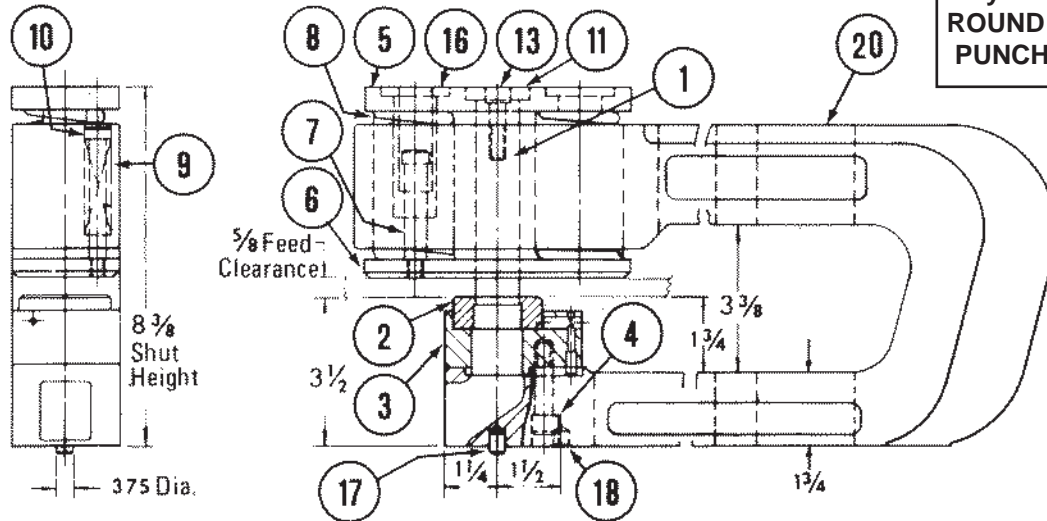

MINIMUM RECOMENDED DIE CLEARANCE .018

ITEM NO.	DESCRIPTION	CATALOG NO.	ITEM NO.	DESCRIPTION	CATALOG NO.
1	Round Punch & Head Ass'y	HHPA-252A	10	Stripper Bolt (Lifter)	3/8x2 1/2" Lg.
—	Round Punch Only	HHP-252	11	Punch Head	HHPH-257
—	Shaped Punch & Head Ass'y	HHPA-252K	12	Punch Key Screw	1/4-20x3/4" B.H.S.
—	Shaped Punch Only	HHP-252K	13	Punch Screw	3/8-24x1 S.H.C.S.
2	Die (Round Hole)	HHD-253	14	Punch Retainer	HHPR-100
—	Die Block (Round)	HHDB-253	15	Punch Ret. Screw & Washer	10-32x1/2 F.H.S.S.
—	Die (Shaped Hole)	HHD-253K	16	Spring Retainer (2 req.)	HHSR-100
—	Die Block (Shaped)	HHDB-253K	17	Pilot Pin - Round	PP-1000
3	Die Holder	HHDH-258K	18	Pilot Pin - Shaped	PP-1000K
4	Bolts for Die Holder	3/8-16x2 S.H.C.S.	19	Punch Key	HHPK-100-1
5	Punch Plate	HHP-250		(Old Style)	HHPK-100
6	Stripper Plate	HHS-259	20	** Holder-8" Throat	8HH-2-1/2 CK
7	Stripper Bolt (2 req.)	1/2x2-1/4" Lg.		** Holder-12" Throat	12HH-2-1/2 CK
8	Stripper Spring (2 req.)	HHSS-255		** Holder-18" Throat	18HH-2-1/2 CK
9	Lifter Spring (2 req.)	HHLS-256		** Holder-24" Throat	24HH-2-1/2 CK
			21	Die Key	GK-100

** Includes PP-1000 and PP-1000K Pilot Pins

ALTERATION TO HH-2½" UNIT FOR PUNCHING CLOSE TO INSIDE LEG OF ANGLE

HH-2½" Standard

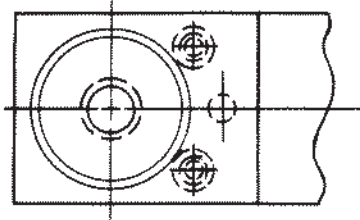

STANDARD DIE
HHD-253 or HHD-253K

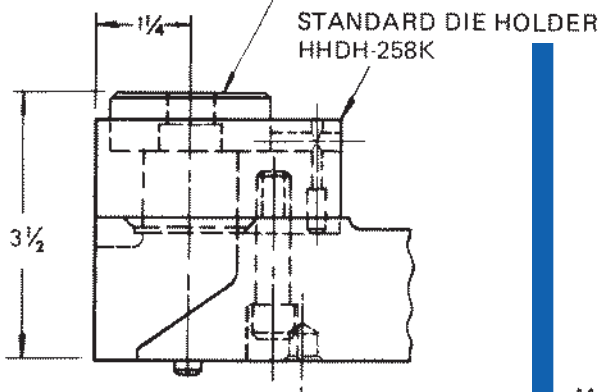

HH-2½" Altered

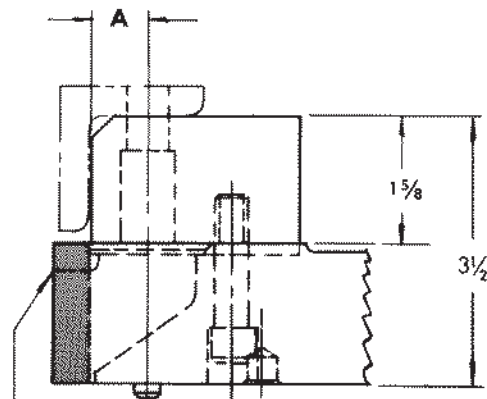
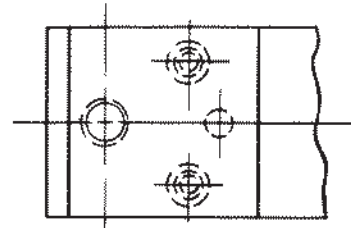

MACHINE FRONT FACE
OF CASTING, IF NECESSARY,
TO CLEAR WORK PIECE

DIE BLOCK

	CATALOG NO.	DIMENSION "A"
ROUND HOLE	HHDB-253	Specify
SHAPED HOLE*	HHDB-253K	Specify

*Note: Shapes are keyed for one position only. Provide sketch to show relation of shaped hole to front of die block.

Die block shown above is designed for punching close to inside leg of angle. The Die Block will fit all Standard HH-2½ units. It may be necessary in some cases, to machine the front face of the holder to clear the work-piece, if the extension of the flange is greater than 1⅝".

The Die Blocks are manufactured to suit application. For price quotation, please specify dimension "A" or send sketch or drawing of workpiece.

WARNING: Operating setup should be guarded to comply with applicable standards for operator safety.

MODEL HH-3"

	CAT. NO.	THROAT DEPTH	HOLDER WIDTH	LENGTH A	LENGTH B	LENGTH C
8³/₈" SHUT HEIGHT	8HH-3	8 ⁵ / ₈	3"	11 ³ / ₄	4 ³ / ₄	—
3¹/₂" DIE HEIGHT	12HH-3	12 ⁵ / ₈	3"	15 ³ / ₄	4 ³ / ₄	—
	18HH-3	18 ⁵ / ₈	3"	21 ³ / ₄	4 ³ / ₄	—

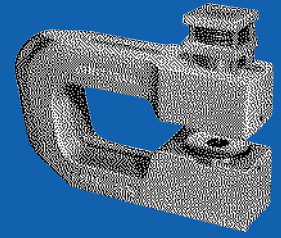

** For Punching up to 3/4" Material*

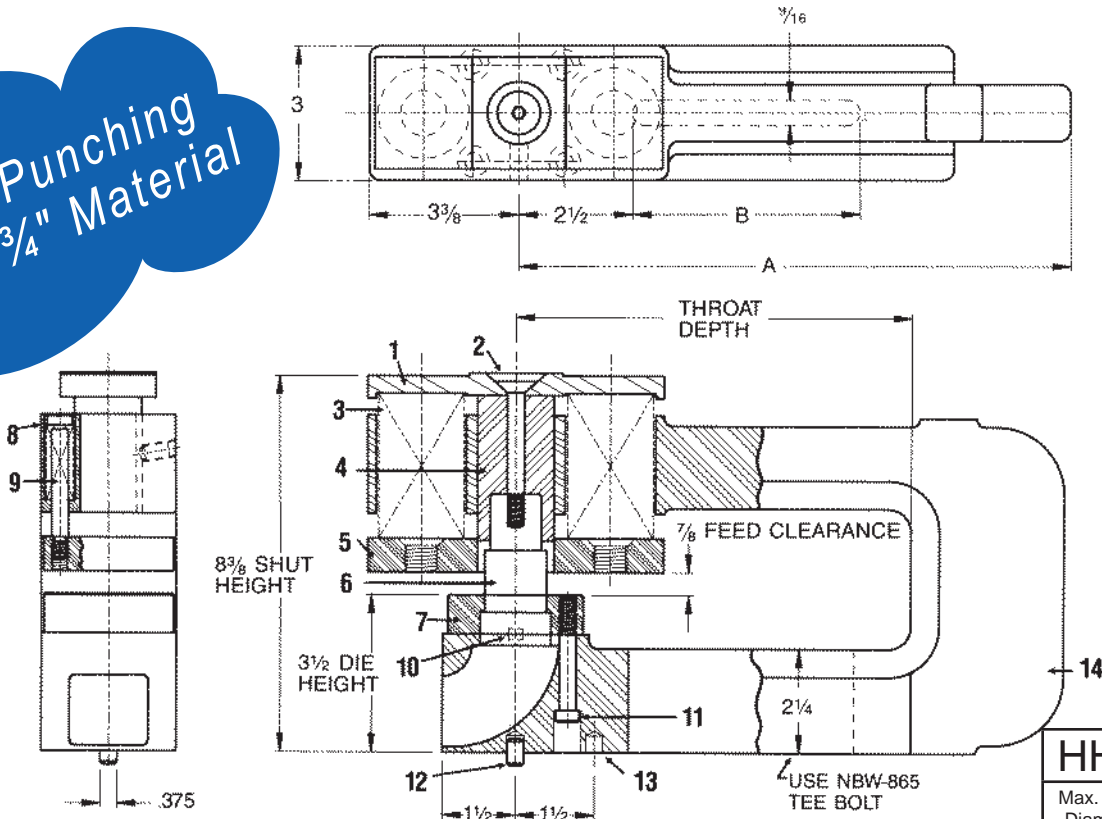

HH-3 UNIT	
Max. Punch Diameter	Max. Material Thickness
1.375	3/8"
1.250	1/2"
1.125	5/8"
1.000	3/4"

* When punching material 5/8" thick and over, Unittool recommends the use of liquid springs to increase Stripping pressure.

MIN. PUNCH SIZE - .406" DIA.

MAX. PUNCH SIZE - 1.375" DIA.

ITEM NO.	DESCRIPTION	CATALOG NO.	ITEM NO.	DESCRIPTION	CATALOG NO.
1	Punch Plate	HHPP-307	14	(1) Holder 8" Throat	8 HH3-CK
2	Punch Screw	5/8-11x3 F.H.C.S.	15	(1) Holder 12" Throat	12 HH3-CK
3	Stripper Spring	HHSS-305		(1) Holder 18" Throat	18 HH3-CK
4	Punch Driver	HHD-309		Punch Key	HPK-302
5	Stripper Plate	HHSP-308	(1) Includes PP-1000 and PP-1000K Pilot Pins		
6	Punch Tip From 1 1/8 to 1 3/8	HHP-302-1	MINIMUM RECOMENDED DIE CLEARANCE .018		
-	Shaped Punch (1.125 to 1.375)	HHP-302-1K			
-	Punch Tip Under 1.125	HHP-302-2			
-	Shaped Punch (under 1.125)	HHP-302-2K			
7	Die	HHD-303			
-	Shaped Die	HHD-303K			
8	Stripper Bolt (Lifter)	3/8x2 1/4 Lg.			
9	Lifter Spring	HHLS-306			
10	Die Key	HHDK-303-1			
11	Die Screws	5/16-18x2 1/2" S.H.C.S.			
12	Pilot Pin	PP-1000			
	Pilot Pin (Diamond)	PP-1000K			
	Pilot Pin (Shaped)	PP-1000K			

**PUNCH RANGE - .375 THRU 2.000 DIA.
CAPACITY: 1.250 DIA. IN 1/2" MILD STEEL
2.000 DIA. IN 1/4" MILD STEEL**

MODEL
HH-3 1/2"

SHUT HEIGHT	CAT. NO.	THROAT DEPTH	HOLDER WIDTH	LENGTH A	LENGTH B	LENGTH C
8 3/8"	8HH-3 1/2	8 5/8	3 1/2	12 1/8	3 1/2	—
3 1/2"	12HH-3 1/2	12 5/8	3 1/2	16 1/8	5 1/2	—
	18HH-3 1/2	18 5/8	3 1/2	22 1/8	5 1/2	5 1/2
	24HH-3 1/2	24 1/8	3 1/2	27 5/8	5 1/2	5 1/2

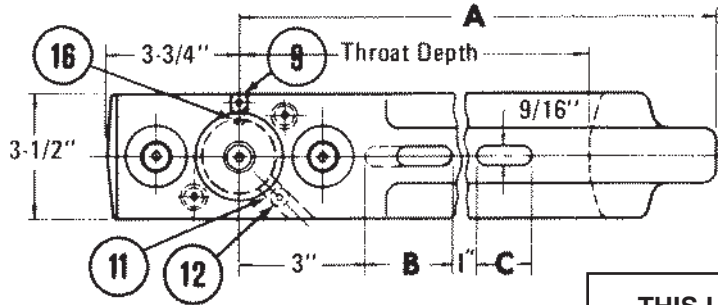
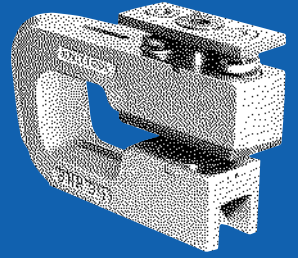

**THIS UNIT IS
KEYED FOR BOTH
ROUND & SHAPED
PUNCHES & DIES**

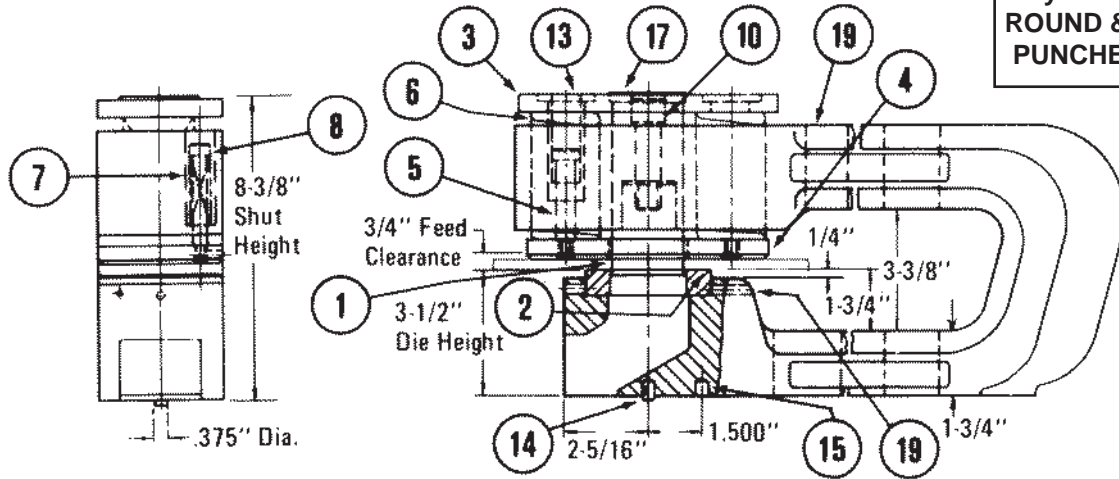

MINIMUM RECOMENDED DIE CLEARANCE .018

ITEM NO.	DESCRIPTION	CATALOG NO.	ITEM NO.	DESCRIPTION	CATALOG NO.
1	Round Punch	HHP-352	11	Punch Retainer	HHPR-100
-	Shaped Punch	HHP-352K	12	Punch Ret. Screw & Washer	10-32x1/2 F.H.S.S.
2	Die (Round Hole)	HHD-353	13	Spring Retainer	HHSR-100
-	Die (Shaped Hole)	HHD-353K	14	Pilot Pin - Round	PP-1000
3	Punch Plate	HHPP-350	15	Pilot Pin - Shaped	PP-1000K
4	Stripper Plate	HHSP-359	16	Punch Key	HHPK-100
5	Stripper Bolt (2 req.)	1/2x2-1/4" Lg.		(Old Style)	HHPK-100-1
6	Stripper Spring (2 req.)	HHSS-255	17	Punch Driver	HHPD-354K
7	Lifter Spring (2 req.)	HHLS-256	18	Die Key	GK-100
8	Stripper Bolt	3/8x2-1/2" Lg.	19	** Holder - 8" Throat	8 HH-3-1/2 CK
9	Punch Key Screw	1/4-20x3/4" B.H.S.		** Holder - 12" Throat	12 HH-3-1/2 CK
10	Punch Screw	5/8-18x2 1/2 S.H.C.S.		** Holder - 18" Throat	18 HH-3-1/2 CK
				** Holder - 24" Throat	24 HH-3-1/2 CK

** Includes PP-1000 and PP-1000K Pilot Pins

**PUNCH RANGE – 1.312 THRU 3.000 DIA.
CAPACITY: 1.500 DIA. IN 1/2" MILD STEEL
3.000 DIA. IN 1/4" MILD STEEL**

MODEL
HH-5 1/2"

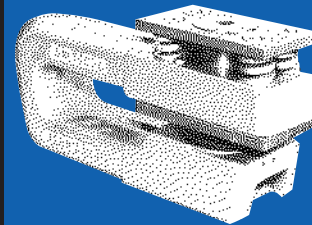

SHUT HEIGHT	CAT. NO.	THROAT DEPTH	HOLDER WIDTH	LENGTH A		
8 3/8"	8HH-5 1/2	8 1/2	5 1/2	13		
	12HH-5 1/2	12 1/2	5 1/2	17		
	18HH-5 1/2	18 1/2	5 1/2	23		
3 1/2"	24HH-5 1/2	24 1/2	5 1/2	28 5/8		

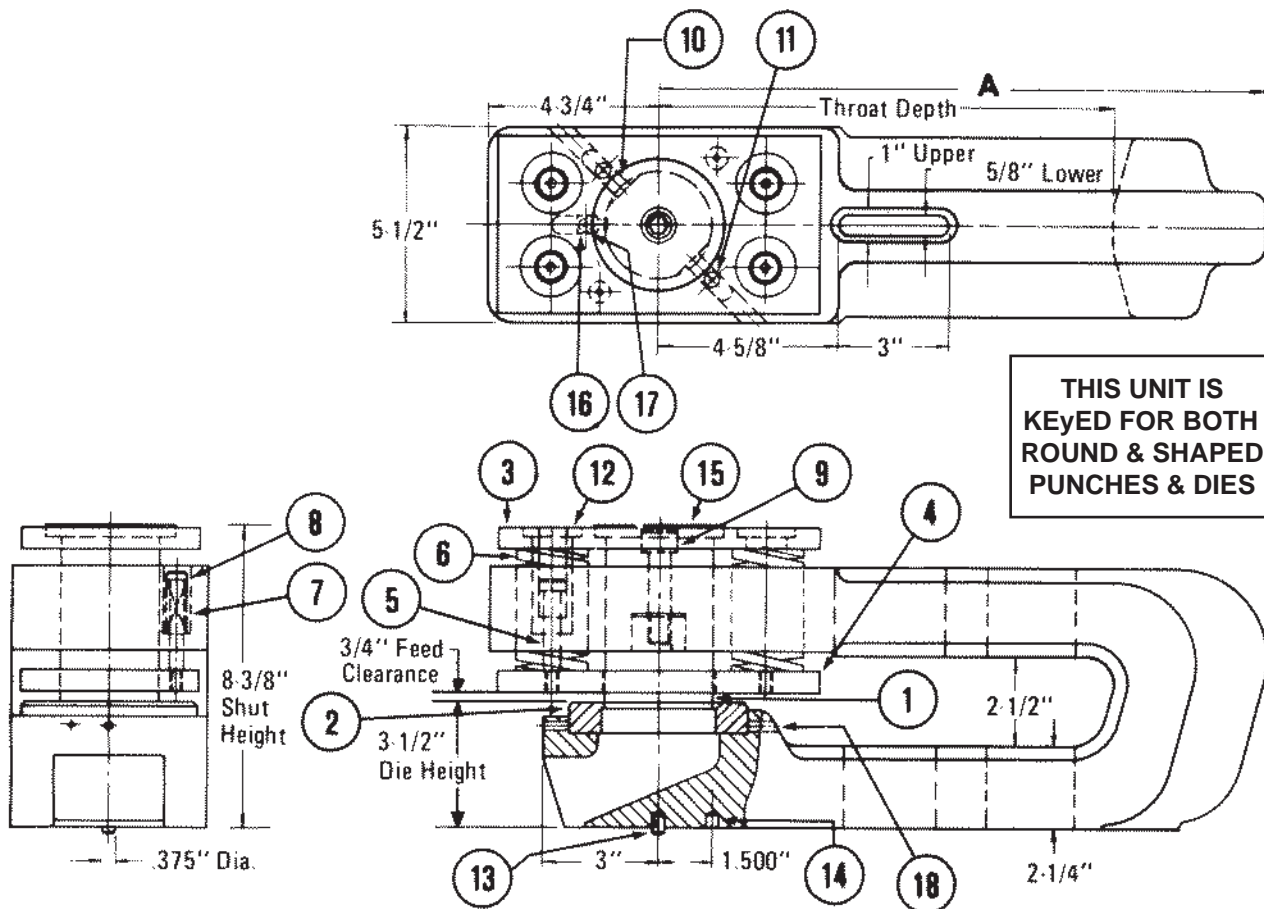

MINIMUM RECOMENDED DIE CLEARANCE .012

ITEM NO.	DESCRIPTION	CATALOG NO.	ITEM NO.	DESCRIPTION	CATALOG NO.
1	Round Punch	HHP-552	11	Punch Ret. Screw & Washer (2 req.)	10-32x1/2 F.H.S.S
-	Shaped Punch	HHP-552K	12	Spring Retainer (4 req.)	HHSR-100
2	Die – Round	HHD-553	13	Pilot Pin	PP-1000
-	Die – Shaped	HHD-553K	14	Pilot Pin - Shaped	PP-1000K
3	Punch Plate	HHPP-550	15	Punch Driver	HHPD-554K
4	Stripper Plate	HHSP-559	16	Punch Key	HHPK-100
5	Stripper Bolt (4 req.)	1/2x2-1/2 Lg.	17	Punch Key Screw	1/4-20x3/4 B.H.S.
6	Stripper Spring (4 req.)	HHSS-255	18	Die Key	GK-100
7	Lifter Spring (2 req.)	HHLS-256	19	** Holder - 8" Throat	8HH-5-1/2 CK
8	Stripper Bolt (2 req.)	3/8x2 1/2" Lg.		** Holder - 12" Throat	12HH-5-1/2 CK
9	Punch Screw	5/8-18x2 1/2 S.H.C.S.		** Holder - 18" Throat	18HH-5-1/2 CK
10	Punch Retainer (2 req.)	HHPR-100		** Holder - 24" Throat	24HH-5-1/2 CK

** Includes PP-1000 and PP-1000K Pilot Pins

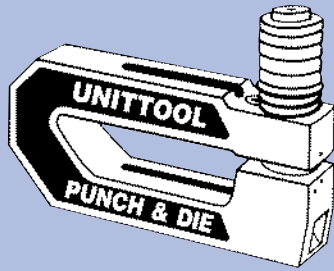

HEAVY DUTY feed thru punching units



round and shaped holes

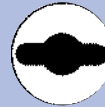

MAXIMUM MATERIAL THICKNESS – 1/4" MILD STEEL

(UP TO 1/2" MILD STEEL FOR MODEL HFT-3 1/2)

Unittool's Heavy Duty Feed Thru Punching Units are recommended for perforating operations where it is desirable to feed the material through from the front or back of the press. This system can also be used to punch holes from the edge of the material that are beyond the reach of "C" frame tooling.

There is no throat depth to be considered with this style of equipment. The assembly can be set up outside of the press, therefore saving valuable press time. The complete bed rail and unit assembly can be placed in the press, ready to operate, in just a few minutes.

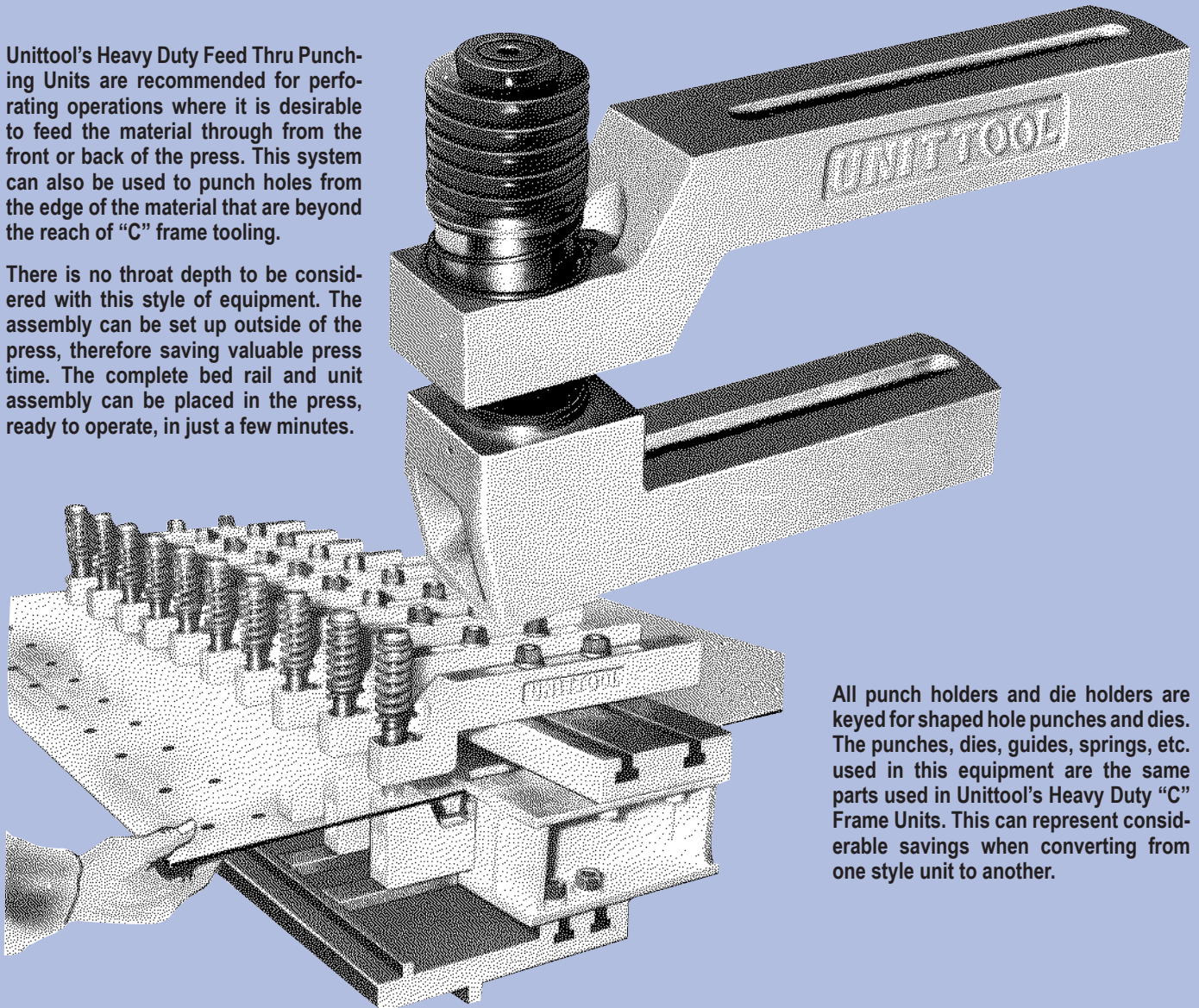

All punch holders and die holders are keyed for shaped hole punches and dies. The punches, dies, guides, springs, etc. used in this equipment are the same parts used in Unittool's Heavy Duty "C" Frame Units. This can represent considerable savings when converting from one style unit to another.

Feed Thru Hole Punching Units

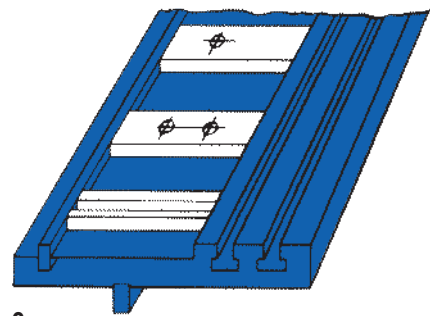
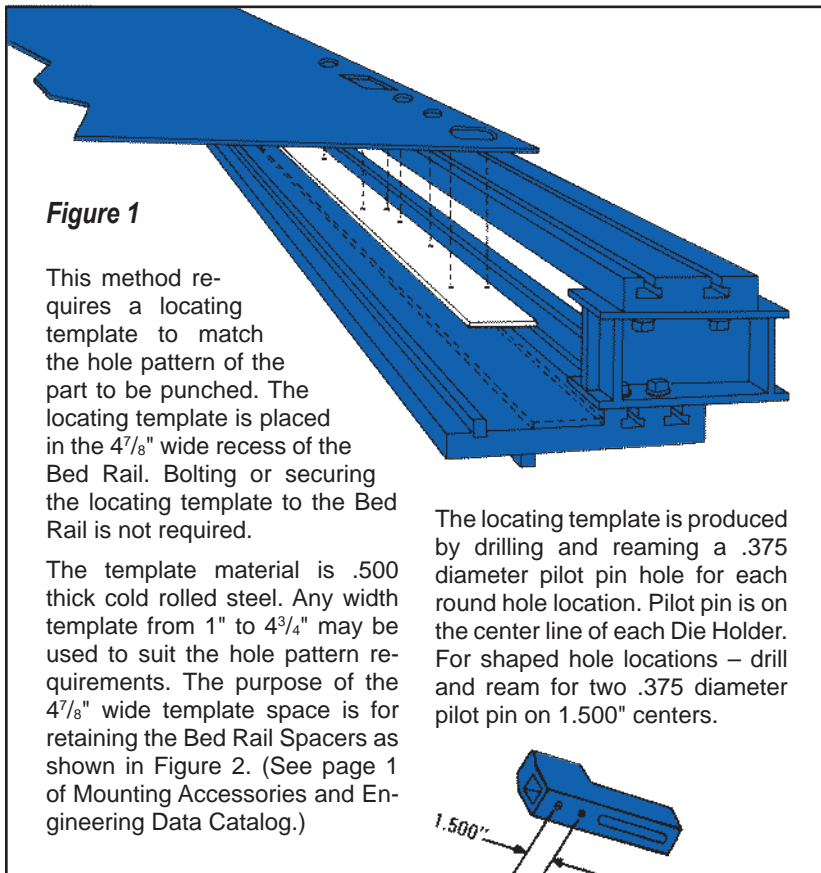

Figure 2

Illustration to show Bed Rail with Bed Rail Spacer that can be used instead of a template. Spacer can be adjusted along the rail to suit a particular hole pattern.

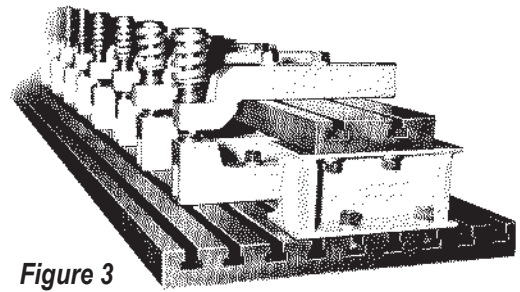

Figure 3

Illustration to show how Upper Bed Rail Assembly can be used with a tee slotted plate. (Ask for quotation.)

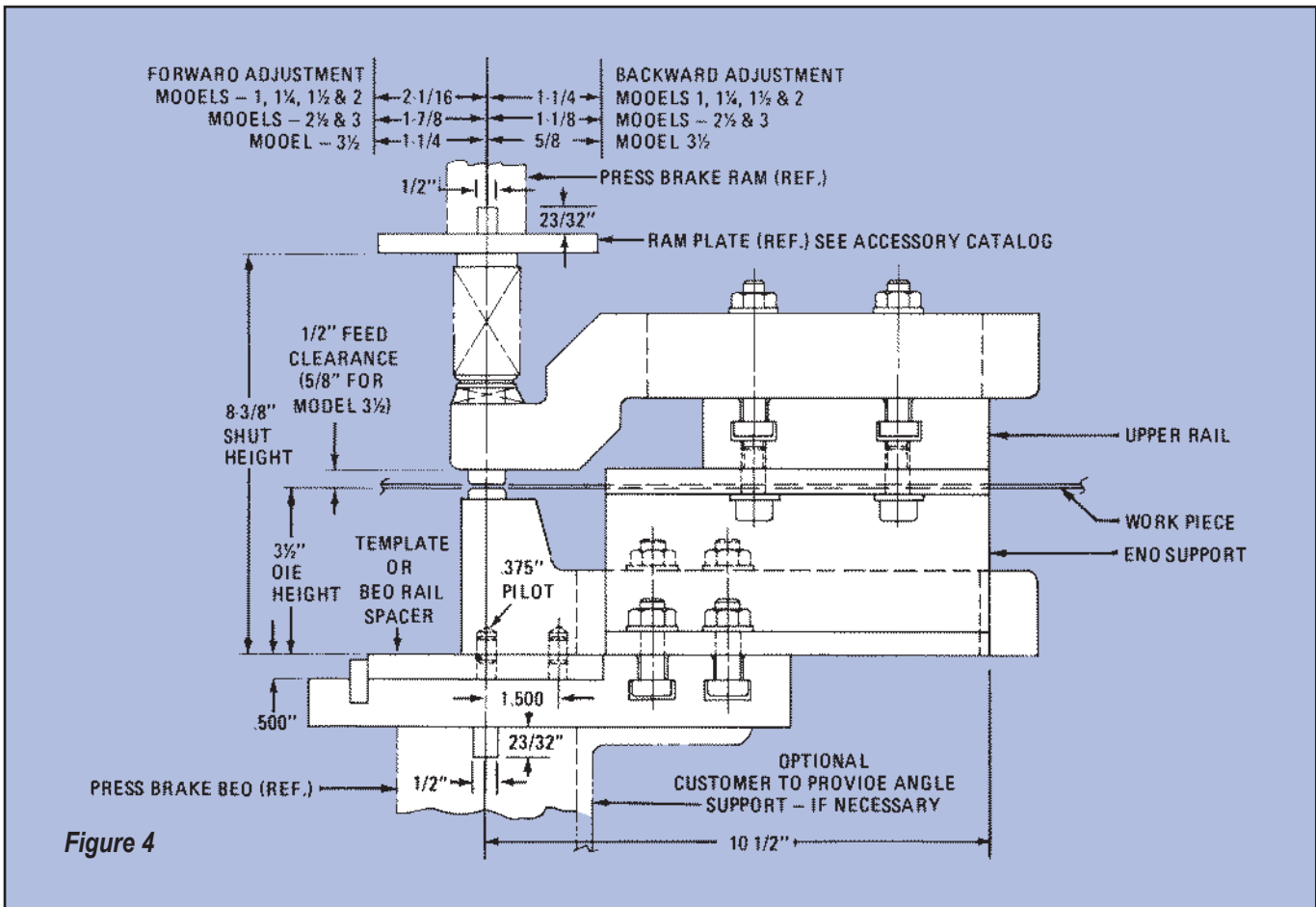
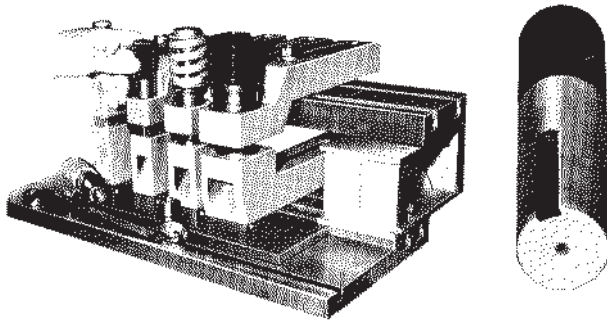

Figure 4

Locator Pins



Locator Pins are used for accurate alignment of punch and die holder. Punch and die holders can also be aligned with LESS accuracy by removing the stripper spring and slipping the punch tip into the die hole. (For models HFT-1 through HFT-2 only.) When aligning HFT-2¹/₂, HFT-3 & HFT-3¹/₂ with the punch tip method, it would be necessary to loosen the punch screw and "tap out" the punch until the punch tip extends beyond the end of the guide.

CAT NO.	FOR USE WITH MODEL NO.
FTLP-125	HFT-1 & HFT-1-1/4
FTLP-150	HFT-1-1/2
FTLP-200	HFT-2
FTLP-250	HFT-2-1/2
FTLP-300	HFT-3
FTLP-350	HFT-3-1/2

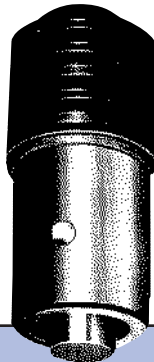
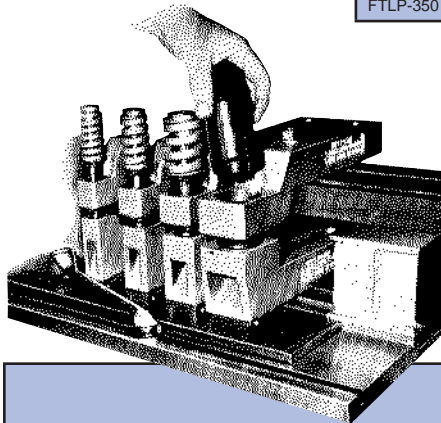

Bed & Rail Assembly

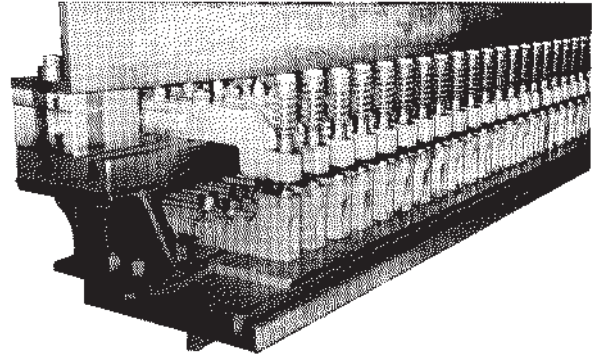

BED & RAIL ASSEMBLY

CAT. NO.	OVERALL LENGTH	INSIDE DIMENSION BETWEEN END SUPPORTS
FTBR-6	7'	6'
FTBR-8	9'	8'
FTBR-10*	11'6"	10'
FTBR-12*	13'6"	12'

*Reinforcement of Upper Rail may be necessary, at additional cost, depending on number of units in setup. Consult factory.



RAM STRIKER PLATE RP-803

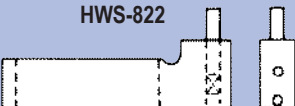

DISAPPEARING PIN STOP HWS-822

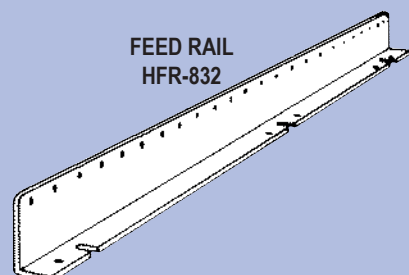

FEED RAIL HFR-832



NUT-BOLT & WASHER SET NBW-843

(Four pieces recommended for each complete punching unit)

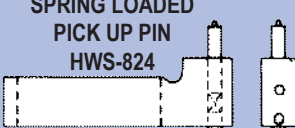

SPRING LOADED PICK UP PIN HWS-824

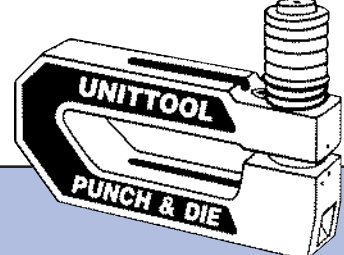

UNITTOOL PUNCH & DIE

SEE MOUNTING ACCESSORIES AND ENGINEERING DATA CATALOG FOR DETAILS AND OTHER INFORMATION.

SPECIFICATIONS

ROUND HOLE MODEL NO.	HFT-1	HFT-1-1/4	HFT-1-1/2	HFT-2	HFT-2-1/2	HFT-3	HFT-3-1/2
SHAPED HOLE MODEL NO.	HFT-1K	HFT-1-1/4K	HFT-1-1/2K	HFT-2K	HFT-2-1/2K	HFT-3K	HFT-3-1/2K
MAX. PUNCH DIMENSION	.4375	.4375	.625	.875	1.500	1.750	2.000
WIDTH OF UNIT	1"	1-1/4"	1-1/2"	2"	2-1/2"	3"	3-1/2"
MAX. MATERIAL THICKNESS (MILD STEEL)	1/4"	1/4"	1/4"	1/4"	1/4"	1/4"	1/2" *

See Current Price Sheet for Detail Information.
The punches, dies, guides, springs, etc. used in Unittool's Heavy Duty Feed Units are interchangeable with Unittool's Model "H" Heavy Duty "C" Frame Units.

*Max. Capacity for HFT-3¹/₂ is as follows = 2" Dia. in 1/4" Thickness – 1⁵/₈" Dia. in 3/8" Thickness – 1¹/₄" Dia. in 1/2" Thickness.

Standard Shapes

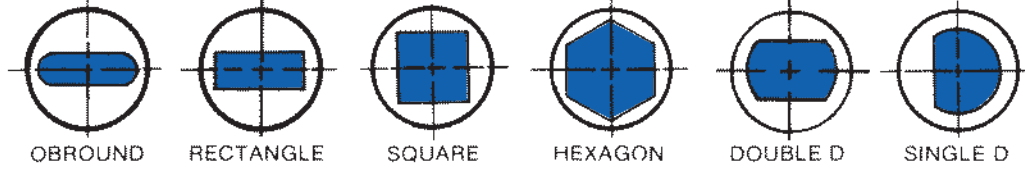

Standard shapes are keyed for both parallel and 90 degree position to the center line of the holder.

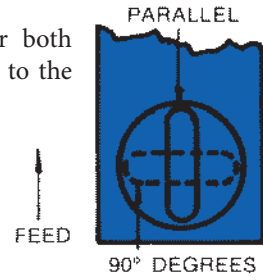

Semi standard and special shapes

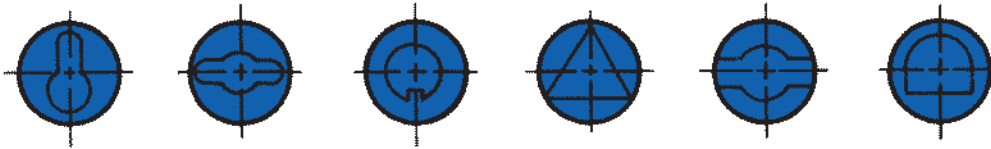

SEND SKETCH FOR PRICE QUOTATION

NOTE: For Shapes that are not symmetrical – specify location of shape in relation to center line of holder so that punches and dies can be properly keyed. Listed below are examples of common special shapes. When ordering, please submit a sketch with dimensions as shown. Also specify material thickness being punched and keying information by (point-X) in relation to the front of the machine.

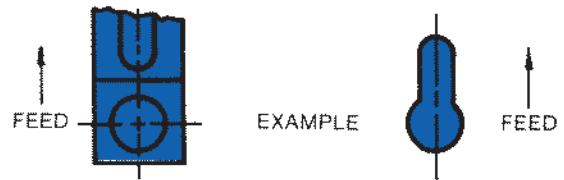

KEYHOLE	HEELED OBRD.	DOUBLE KEYHOLE	SINGLE "D"	KEYWAY

Keying arrangements

For converting round hole unit for shaped hole punching – See conversion kit listed at bottom of price list.

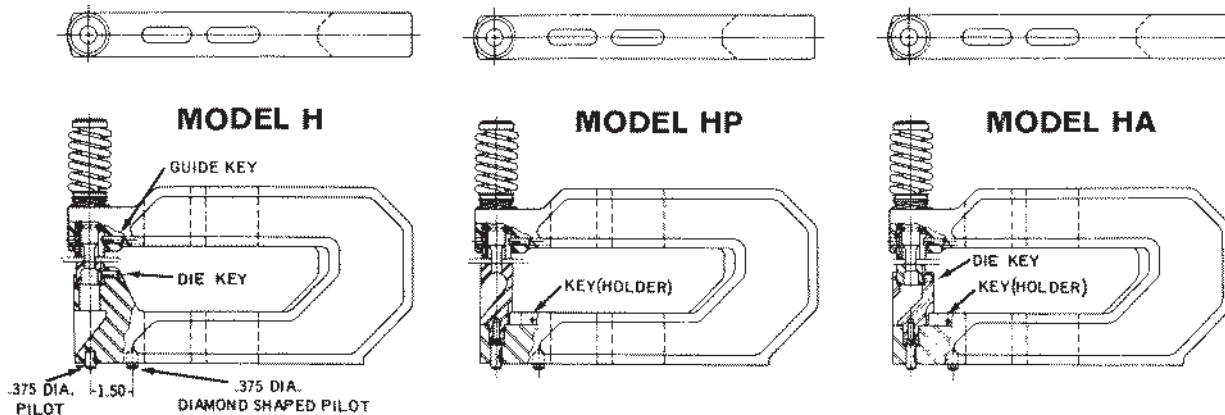

Compensator caps for H1, H1¼, H1½ & H2 units

Compensator Caps are used to stagger punching load when available press tonnage is marginal. The caps alter the punch assembly length and cause the punch tips to enter the material at different intervals, thereby reducing the required tonnage accordingly. The disadvantage of using compensator caps is that it overworks the stripping springs because of additional punch assembly length. Caution must be exercised to prevent "bottoming." New or full length punches and dies are recommended when using compensator caps in order to keep the press shut height at a maximum.

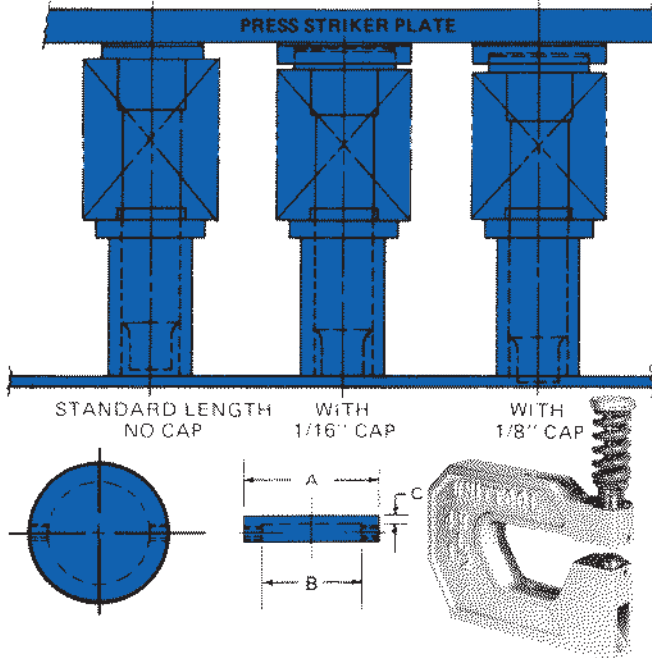

MODEL	A	B	C	PART NO.
H1, H1¼	1-1/2	1-1/32	1/16 1/8	CC-125-062 CC-125-125
H1½	1-3/4	1-9/32	1/16 1/8	CC-150-062 CC-150-125
H2	2	1-17/31	1/16 1/8	CC-200-062 CC-200-125

CHART TO SHOW HOW DIFFERENT COMBINATIONS CAN BE USED:

Material Thickness To Be Punched	Compensator Cap Thickness	Approx. % of Full Tonnage Req'd	Number of Punches Capped
1/16	1/16	50	1/2 (50%)
1/8	1/16	50	1/2 (50%)
1/8	1/8	50	1/2 (50%)
1/8	1/16 & 1/8	33-1/3	2/3 (66.6%) 1/3 w 1/16" Cap 1/3 w 1/8" Cap
3/16	1/16	50	1/2 (50%)
3/16	1/8	50	1/2 (50%)
3/16	1/16 & 1/8	33-1/3	2/3 (66.6%) 1/3 w 1/16" Cap 1/3 w 1/8" Cap
1/4 *	1/8	50	1/2 (50%)
1/4 *	1/16 & 1/8	40	2/3 (66.6%) 1/3 w 1/16" Cap 1/3 w 1/8" Cap
*Use extreme caution on 1/4" material.			

Punch adapter guides for H-Series

Punch Adapter Guides are used to convert a larger unit for use with smaller and less expensive punches. For example:- the HPA-122A punch assembly for the H1¼ unit can be used in the H1½ or H2 unit for punching hole sizes of 7/16" and smaller – the HPA-152A punch can be used in the H2 unit for punching hole sizes 5/8" and smaller – a savings of 10% to 50% can be realized with this method.

The Punch Adapter Guides are available for round or shaped hole punches. The only components required to convert a larger unit for use of smaller punches are: Punch Adapter Guide, Punch and Head Assembly and Stripper Spring.

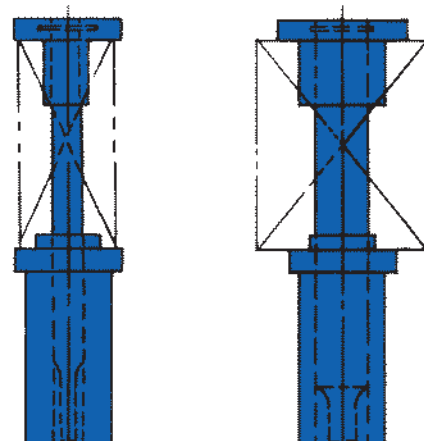

	Punch Adapter Guide Number	Adapts Punch Assembly Number	For Use with Punch Assembly	Max. Punch Tip Dimension	Use Stripper Spring Number
FOR ROUND HOLE UNIT	SHG-122-154	HPA-122A from H1¼ Holder to H1½ Holder	HPA-122A	.4375	HSS-125
	SHG-122-204	HPA-122A from H1¼ Holder to H2 Holder	HPA-122A	.4375	HSS-125
	SHG-152-204	HPA-152A from H1½ Holder to H2 Holder	HPA-152A	.625	HSS-155
FOR SHAPED HOLE UNIT	SHG-122-154K	HPA-122K from H1¼K Holder to H1½K Holder	HPA-122K	.4375	HSS-125
	SHG-122-204K	HPA-122K from H1¼K Holder to H2K Holder	HPA-122K	.4375	HSS-125
	SHG-152-204K	HPA-152K from H1½K Holder to H2K Holder	HPA-152K	.625	HSS-155

Catalog HEF-94

HEF 1 1/4" ROUND OR SHAPED HOLE PUNCHING UNITS

Heavy Duty 1 1/4" Feed Clearance Units:
Shut Height 8 3/8" • Die Height 3 1/2"
Maximum Material Thickness: 1/8"

	HEF - 1 1/4	HEF - 1 1/2	HEF - 2 1/4
	PUNCH SIZE: Max.: .4375 Min.: .093	PUNCH SIZE: Max.: .625 Min.: .125	PUNCH SIZE: Max.: .875 Min.: .187
COMPLETE ASSEMBLED UNITS Includes Punch & Die (P = Pedestal Die Style) (A = Die Adapter Style)	1 1/4" WIDE Catalog No.	1 1/2" WIDE Catalog No.	2 1/4" WIDE Catalog No.
	HEF - 1 1/4P HEF - 1 1/4A HEF - 1 1/4KP HEF - 1 1/4KA	HEF - 1 1/2P HEF - 1 1/2A HEF - 1 1/2KP HEF - 1 1/2KA	HEF - 2 1/4P HEF - 2 1/4A HEF - 2 1/4KP HEF - 2 1/4KA
	PARTS		
	1. PUNCH HEAD 2. SHAPED PUNCH ASS'Y 2. ROUND PUNCH ASS'Y 2. ROUND PUNCH ONLY 3. ROUND DIE 3. SHAPED DIE 4. ROUND GUIDE 4. KEYED GUIDE 5. ROUND PEDESTAL DIE 5. SHAPED PEDESTAL DIE 6. ROUND DIE ADAPTER 6. KEYED DIE ADAPTER 7. STRIPPER SPRING 8. LIFTER SPRING 9. PILOT PIN (Round) 10. GUIDE OR DIE KEY 11. DIE ADAPTER KEY 12. PILOT PIN (Diamond) 13. SHAPED HOLDER 8" THROAT DEPTH	HEFPH - 127 HEFPA - 122K HEFPA - 122A HEFP - 122 HD - 123 HD - 123K HEFG - 124 HEFG - 124K HPD - 123 HPD - 123K HDA - 128 HDA - 128K HEFSS - 125 HEFLS - 126 UPP - 1000 GK - 100 HK - 100 PP - 1000K HEF - 1 1/4CK	HEFPH - 157 HEFPA - 152K HEFPA - 152A HEFP - 152 HD - 153 HD - 153K HEFG - 154 HEFG - 154K HPD - 153 HPD - 153K HDA - 158 HDA - 158K HEFSS - 155 HEFLS - 156 UPP - 1000 GK - 100 HK - 100 PP - 1000K HEF - 1 1/2CK

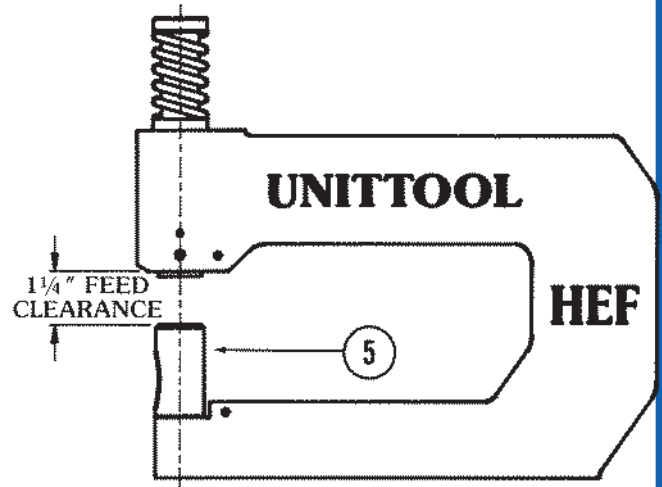

Previously Unittool Punch & Die Company manufactured punching ("C Frame") units with a 1 1/4 inch feed clearance as a special application. Now Unittool is including the 1 1/4 inch feed clearance units (HEF) as a product line series.

The HEF product line series offers extra high feed openings that allow Front Feeding of shaped parts such as angles, channels, extension, etc. The HEF product line series is available to punch round or shaped holes and is supplied in three different widths, namely 1 1/4, 1 1/2 and 2 1/4. The punch size maximum range is .437, .625 and .875 dia. For special applications send drawings with specifications for a price quotation.

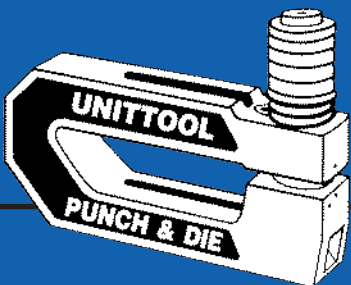
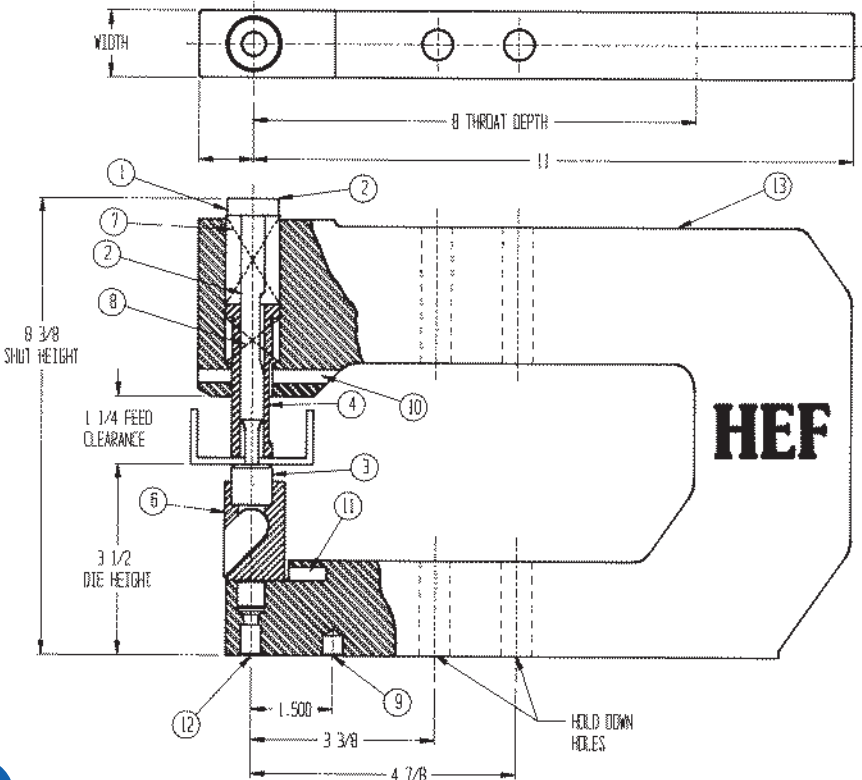

UNITTOOL PUNCH & DIE CO., INC.
PHONE: (716) 873-8453 • FAXLINE: (716) 873-8694 OR (800) 25-PUNCH

FACTORY ADDRESS | 20 NORRIS STREET
BUFFALO, NEW YORK 14207

MAIL ADDRESS | P.O. BOX 863
BUFFALO, NEW YORK 14240

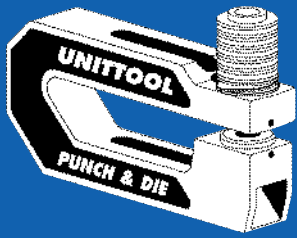

UNITTOOL

Leading Manufacturer of Unitized Tooling

NEW 1³/₄" FEED UNITS

	HEXF—1 ³ / ₄	HEXF—2	HEXF—2 ³ / ₄
	PUNCH SIZE: MAX.: .437 MIN.: .093	PUNCH SIZE: MAX.: .625 MIN.: .125	PUNCH SIZE: MAX.: .875 MIN.: .187
COMPLETE ASSEMBLED UNITS Includes Punch & Die (P = Pedestal Die Style)	WIDE Catalog No.	WIDE Catalog No.	WIDE Catalog No.
	HEXF 1 ³ / ₄	HEXF 2	HEXF 2 ³ / ₄
	HEXF 1 ³ / ₄ P	HEXF 2 P	HEXF 2 ³ / ₄ P
	HEXF 1 ³ / ₄ K HEXF 1 ³ / ₄ K P	HEXF 2 K HEXF 2 K P	HEXF 2 ³ / ₄ K HEXF 2 ³ / ₄ K P

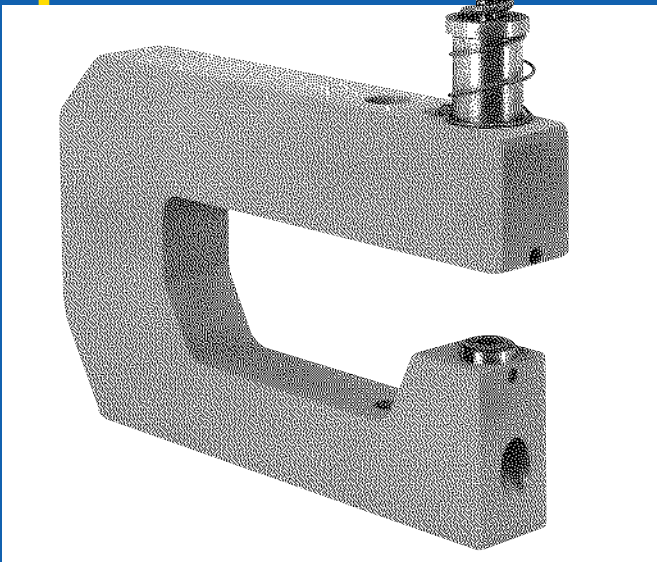

HEXF

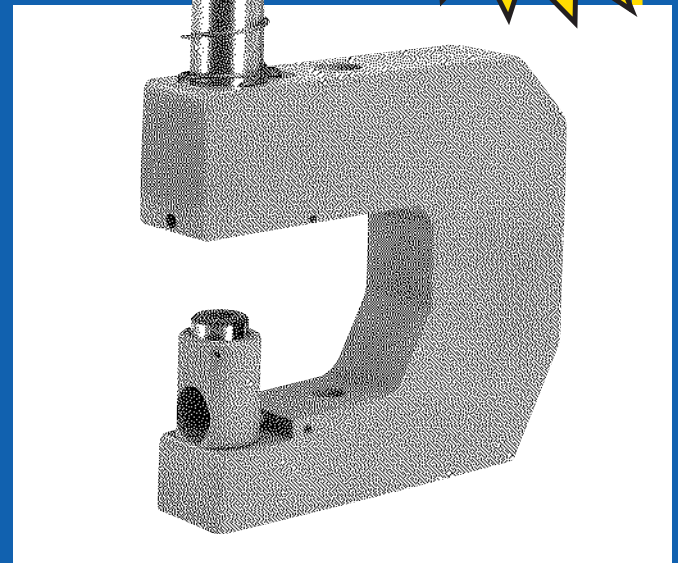

HEXF-P

UNITTOOL PUNCH & DIE CO., INC.

Factory address: 20 Norris St. Buffalo, NY 14207 • Mailing address: P.O. Box 863 Buffalo, NY 14240

Phone: (716) 873-8453 • Fax: (800) 25-PUNCH

Canada division: 151 Cushman Rd. St. Catharines, Ont. L2R 7J9 • Phone: (905) 685-4276 • Fax: (800) 767-6743